

**Razvoj i proizvodnja integrisanih  
Holovih magnetskih senzora  
korisćenjem usluga *silicon foundry***

**Radivoje S. Popović  
EPFL, Lozana, Švajcarska; Senis AG, Zug, Švajcarska;  
i Sentronis AD, Niš, Srbija**

# Motivacija

Fabrika čipova u Srbiji bi verovatno bila dodatak ATIC-ovoj grupi fabrika GLOBALFOUNDRIES. Ako bude tako, onda bi bilo korisno razumeti kako potencijalne mušterije koriste usluge jedne Silicon Foundry; i na kakve teškoce nailaze u tom procesu. U tom smislu, ja ovde pričam o svom iskustvu o razvoju i proizvodnji nekoliko integrisanih magnetskih senzora uz korišćenje usluga silicon foundries.

## Prosireni sažetak

Struktura Holovih elementa je takva da oni mogu da se proizvedu pomocu tehnologije integrisanih kola. U istom cipu se mogu integrisati i Holovi elementi i potrebna elektronika za merenje vektora magnetskog polja. Zbog toga su integrisana kola sa Holovim elementima danas najvise korisceni magnetski senzori.

Razvoj novih integrisanih Holovih senzora se najcesce odvija uporedo sa njihovim novim primenama. Zato se tim poslom cesto bave ljudi izvan poluprovodnicke industrije. Oni za svoje ciljeve koriste tehnologiju integrisanih kola preko usluga *silicon foundry*. Medjutim, procesna dokumentacija koju *silicon foundries* stavljaju na raspolozenje svojim korisnicima je optimizovana za razvoj elektronskih kola, i ne obuhvata sve podatke potrebne za razvoj Holovih senzora. Na primer, da bi se optimizovao dizajn Holovih elemenata, potrebno je znati profile koncentracije primesa vecine slojeva u integrisanom kolu. Takva informacija nije nuzna pri razvoju elektronskih kola, pa nije ni obuhvacena dokumentacijom. Zato razvoj Holovih integrisanih senzora cesto obuhvata in delimicni *reverse engineering* procesa proizvodnje integrisanih kola, koji ima za cilj otkrivanje nepoznatih parametara tog procesa.

Da bi Holovi magnetski senzori postali pogodni za resavanje nekih tehnickih problema, potrebno je da se oni kombinuju sa delovima napravljenim od feromagnetskog materijala. To moze da se postigne integracijom feromagnetskog sloja na površini pločice sa integrisanim Holovim sensorima. Ali takva integracija nije kompatibilna sa uobicajenim procesom proizvodnje *silicon foundry*, pa mora da se resi kroz *post-processing*.

U predavanju ce biti pokazani primeri resavanja ovih i slicnih problema u razvoju nekoliko integrisanih Holovih senzora, koji se koriste kao sonda tri-aksijalnog teslametra, kao senzor ugla u auto-industriji, za bezkontaktno merenje elektricne struje, i kao kompas u mobilnim telefonima.

# Outline

- **Why Integrated Hall Magnetic Sensors?**
- **Development of Hall Sensor ASICs**
- **Reverse Engineering of Silicon Foundry Process**
- **Post-Processing of Hall ASIC Wafers**
- **Applications of Hall Sensor ASICs**
  - **3-Axis Hall Probes for Teslameters**
  - **Current Sensor ASICs**
  - **Angular Position Sensors**
  - **Compass Chips**
- **Conclusions**

# The Hall Effect

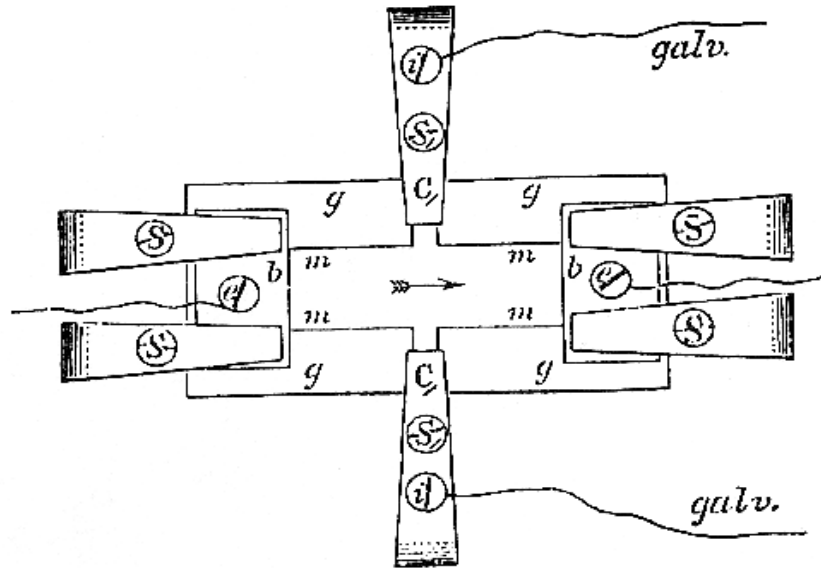

Edwin Hall:

“On a new action of the magnet on electric current” Am.J.Math. 2 (1879) pp.287-92

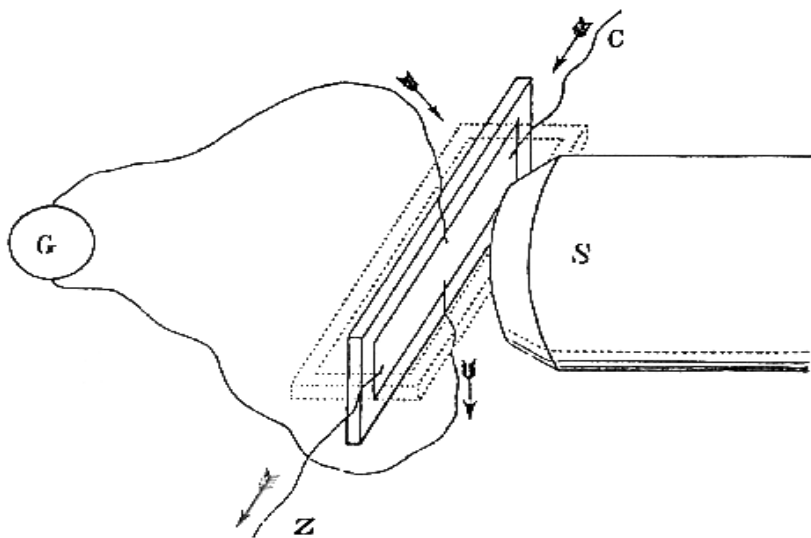

$$V_H \propto I \cdot B$$

# Conventional Integrated Hall Element

- Sensitive to the perpendicular field component  $B$
- CMOS Technology: N-Well
- Depletion layer isolation

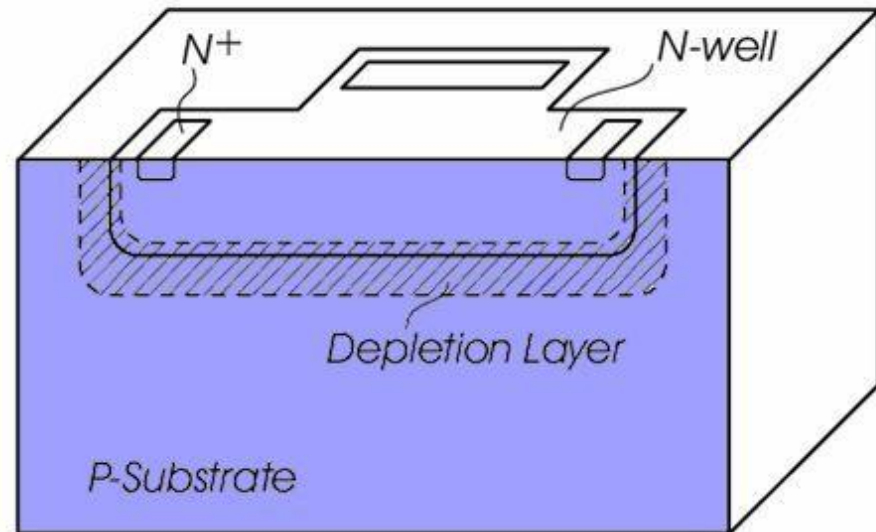
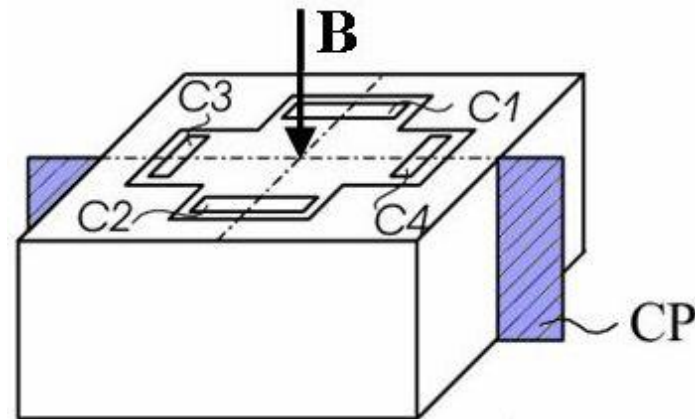

# A Hall Magnetic Sensor ASIC

1: 4 × Hall

2: Memory

3: Output Ampl.

4: Rev. Polar. D.

5: Diagnostics

(Infineon Technologies)

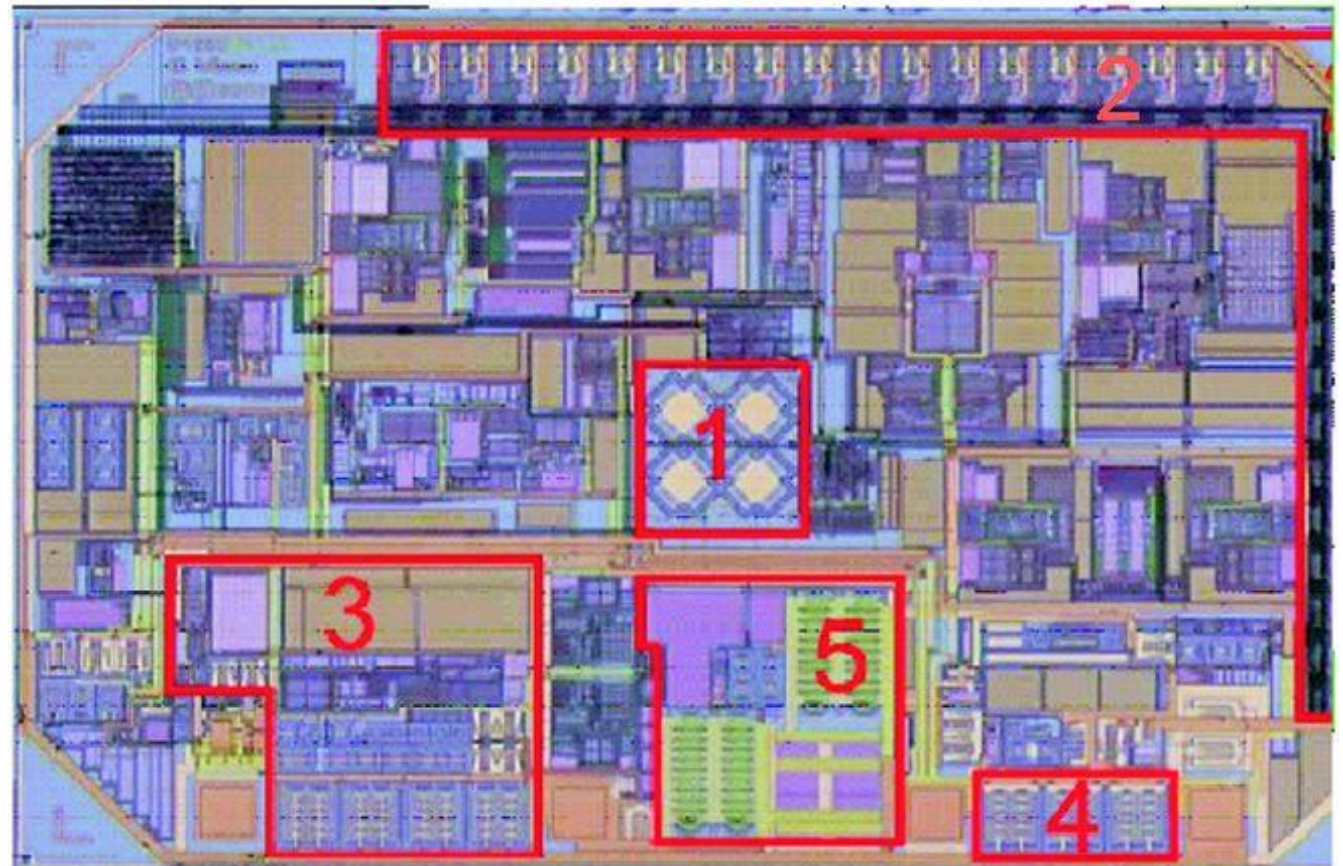

# Market of Silicon Magnetic Sensors

- Growth 9% pa
- Automotive & Compass: 70%
- 85% Hall ASICs

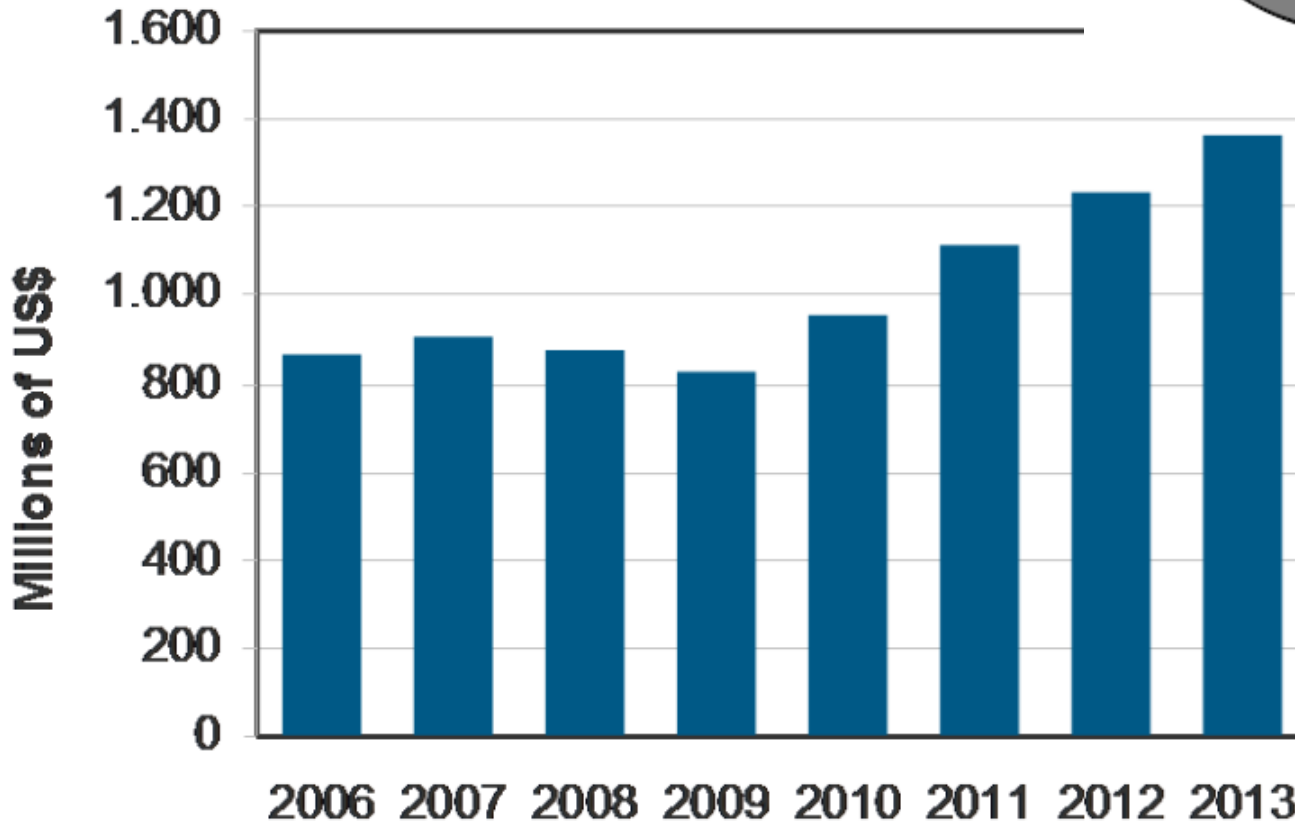
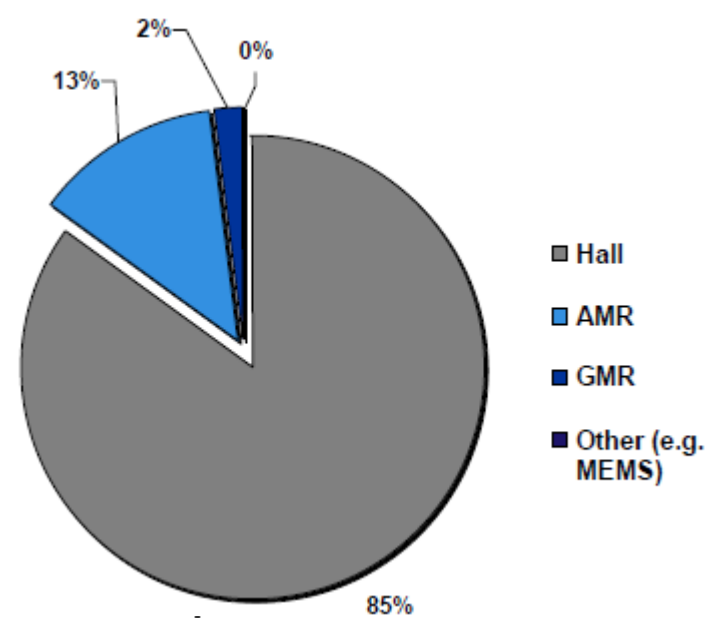

Source:  
*IHS iSuppli*



# Magnetic Sensors in a Car

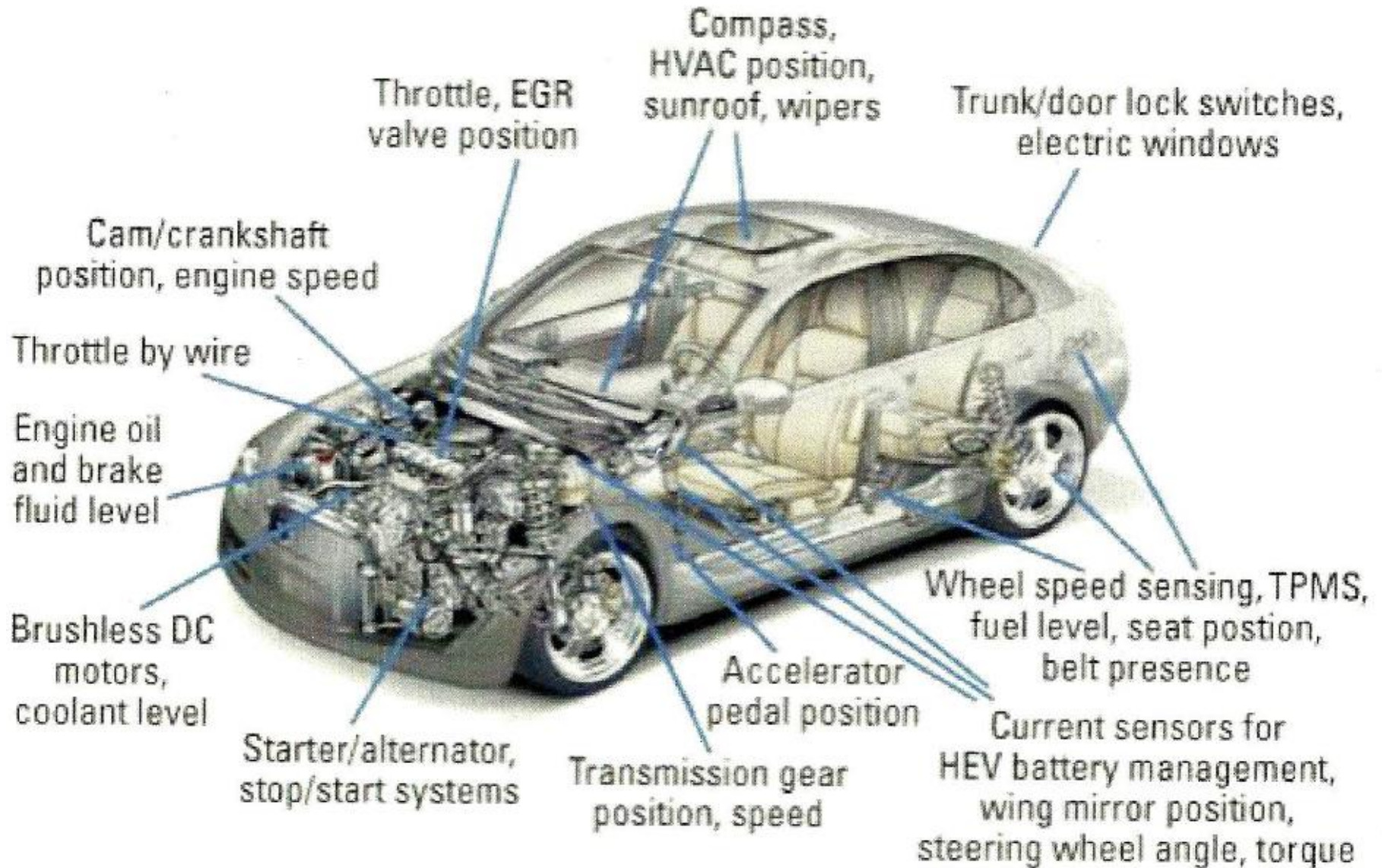

# E-Compass in Cell Phones



Global Shipments of Magnetic Sensors for Electronic Compasses in Cell Phones

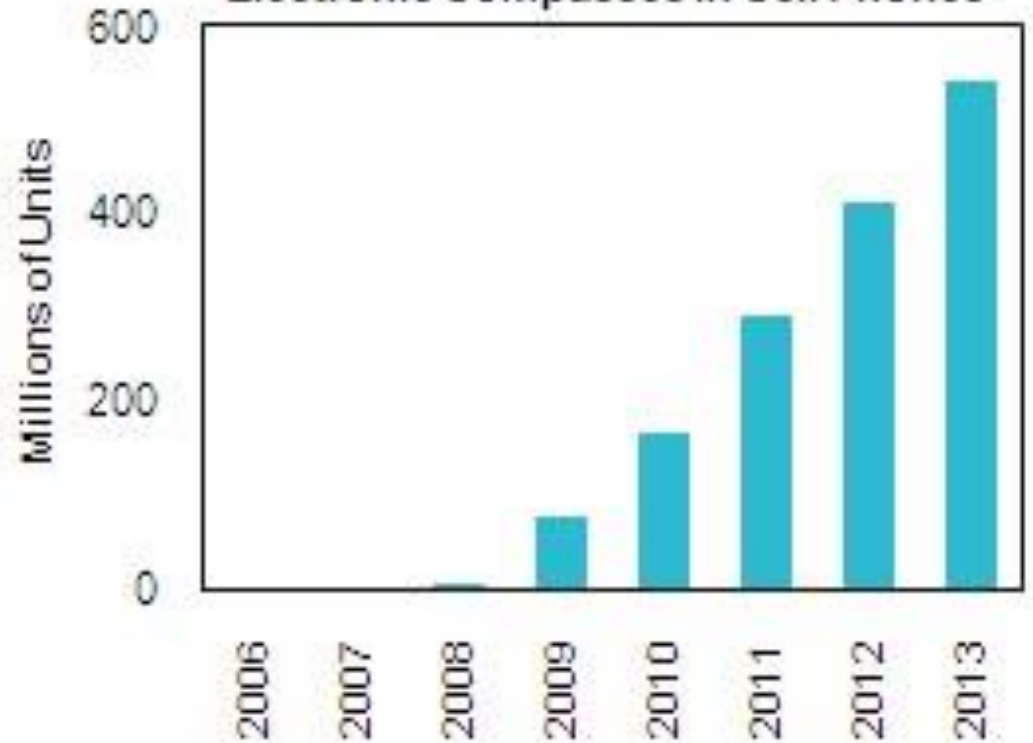

Asahi Kasei Microdevices (AKM):

- 3-axis single-chip electronic compass for portable appliances, the AK8975B
- Comprising **Si monolithic Hall elements and a magnetic concentrator**
- **AKM holds 95 percent share of the mobile phone compass market**

# Development of Integrated Magnetic Sensors (1)

- Motivated and inspired by new applications
- Multidisciplinary task
- Happens mostly outside of the the main-stream semiconductor industry
- Development and production is based on services of silicon foundries
- Design support by silicon foundry:
  - Process parameters
  - Design rules
- MPW runs, Engineering runs
- Small-scale production

# Development of Integrated Magnetic Sensors (2)

But:

- Silicon foundries are organized to support design and production of electronic ICs, not magnetic sensors

Therefore:

- Development of advanced Hall ICs includes retrieval of the missing parameters by partial reverse engineering of the foundry's manufacturing process
- In some cases, post-processing of the finished IC wafers, additional testing, and/or special packaging of the sensor dies are needed.

# Magnetic Sensitivity of a Hall Device

- Absolute Sensitivity:  $S_A = \left| \frac{V_H}{B_\perp} \right|_c$
- Relative Sensitivity

Current-related:

Voltage-related:

$$S_I = \frac{S_A}{I} = \left| \frac{1}{I} \frac{V_H}{B_\perp} \right| \quad S_V = \frac{S_A}{V} = \left| \frac{1}{V} \frac{V_H}{B_\perp} \right| = \frac{S_I}{R_{in}}$$

$$S_I = G_H \frac{|R_H|}{t}$$

$$R_{Hn} = -\frac{1}{qn}$$

$$S_V = \mu_H \frac{w}{l} G_H$$

⇒ **Designer needs data on doping and mobility**<sub>13</sub>

# 0.35 $\mu\text{m}$ 50V CMOS Process Parameters

## Wafer Cross-Section

### 2.2.2 Isolated low voltage (3.3V and 5 V) NMOSI and PMOSI transistors

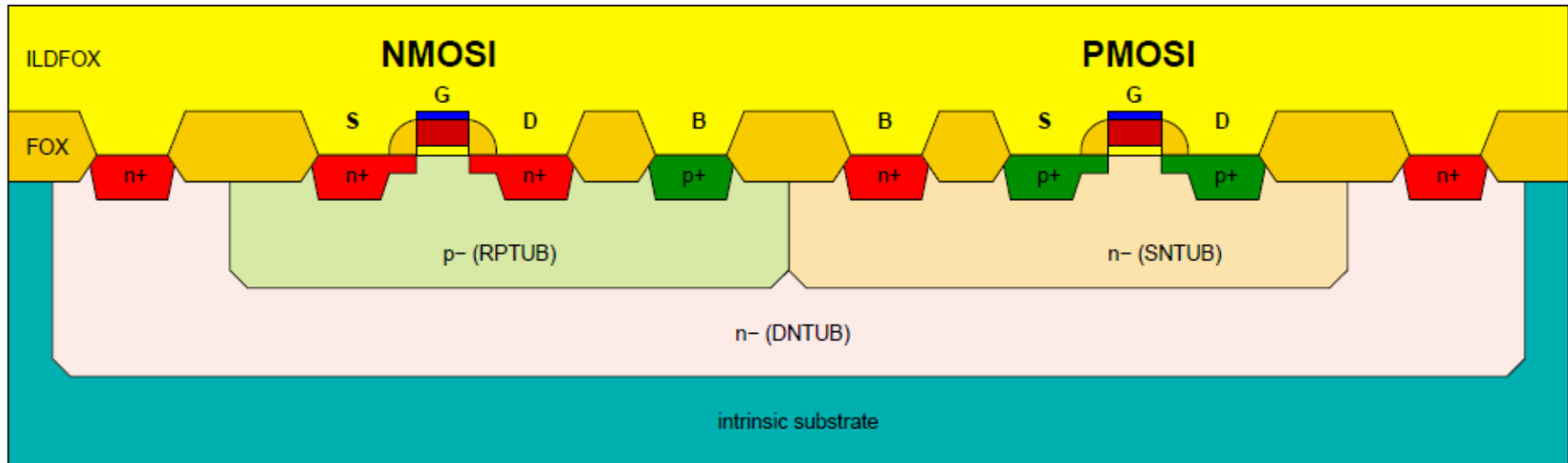

#### Available Parameters

- Sheet resistances
- Junction depths
- Electrical characteristics of transistors and diodes

# Reverse Engineering of IC Manufacturing Process

- Study of available process information
- Synthesis of a hypothetical IC manufacturing process
- Design of adequate test structures
- Manufacturing the test structures through MPW runs
- Measuring the test structures
- Numerical simulations of a hypothetical IC process
- Numerical simulations of reference devices
- Comparison simulation – measurement
- Refinement of the hypothesis

 ... and so on, in several iterations

(Collaboration with Prof. Dragan Pantic of Uni Nis)

# Spreading Resistance Measurements - DNTUB

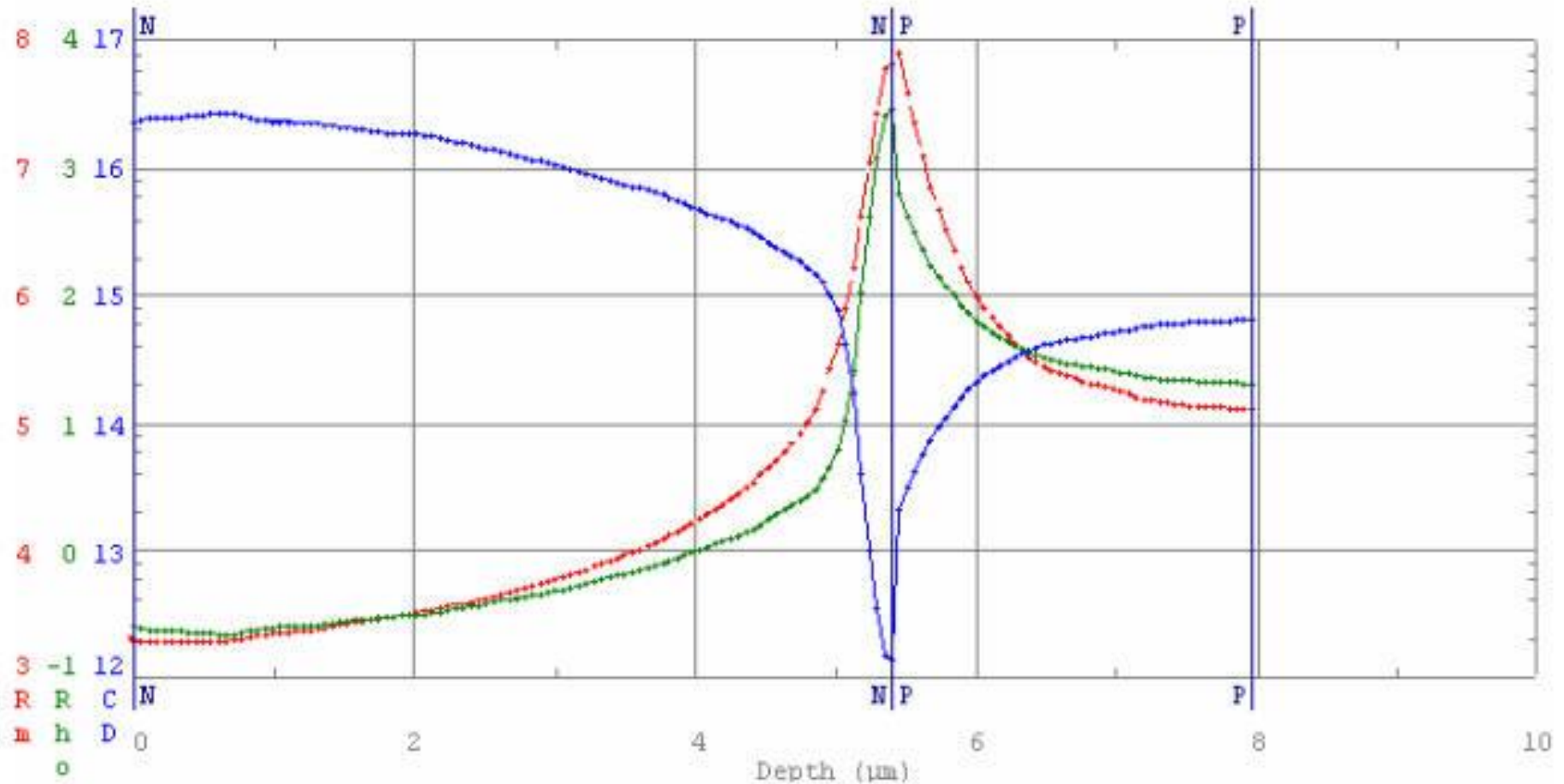
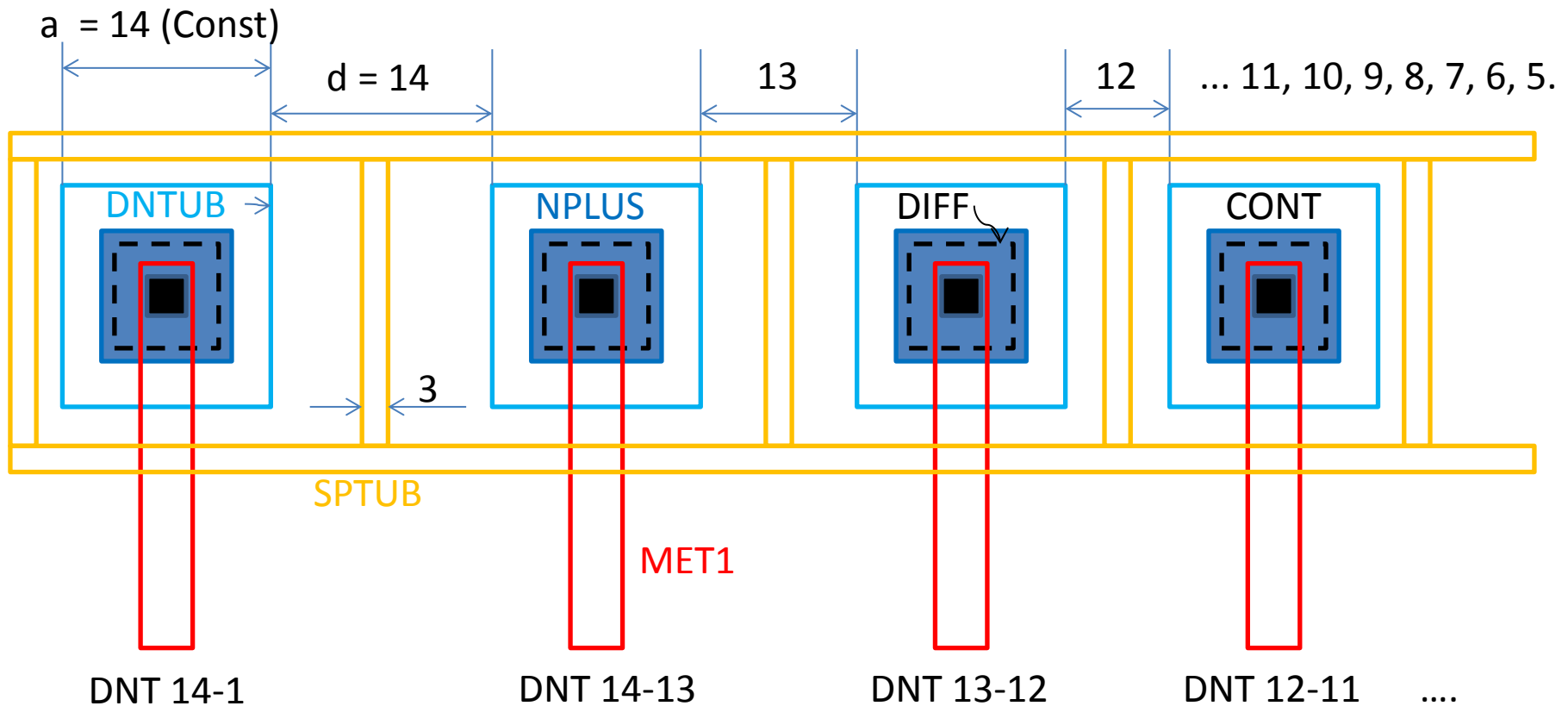

Figure 2: pattern DN  
 measured resistance (red); resistivity (green); carrier concentration (blue)



# Test Structures for Measuring the DNTUB Lateral Diffusion Depth



10 Pads

# Layout of the Hall test chips

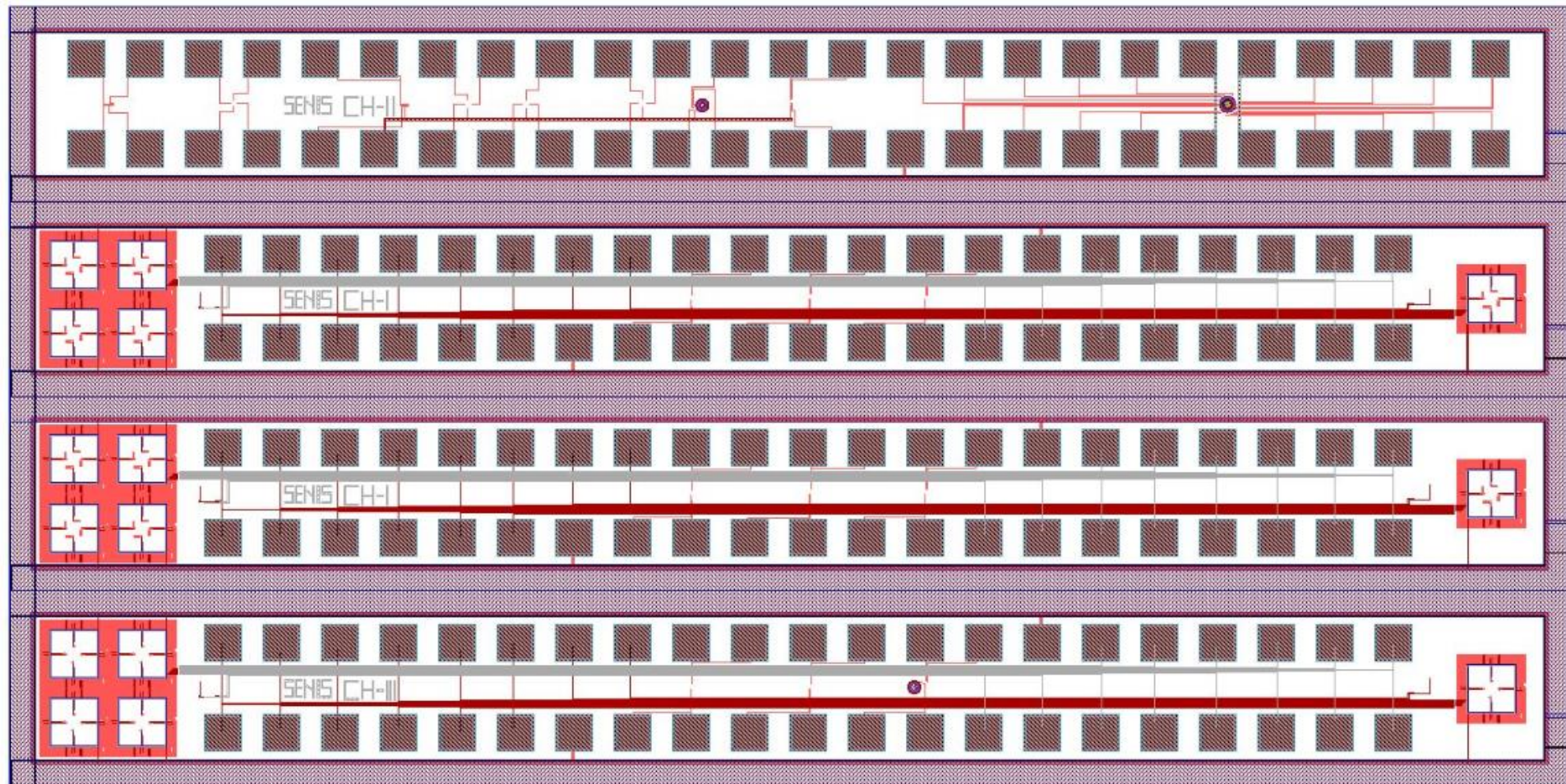

# Bonded Hall test chip

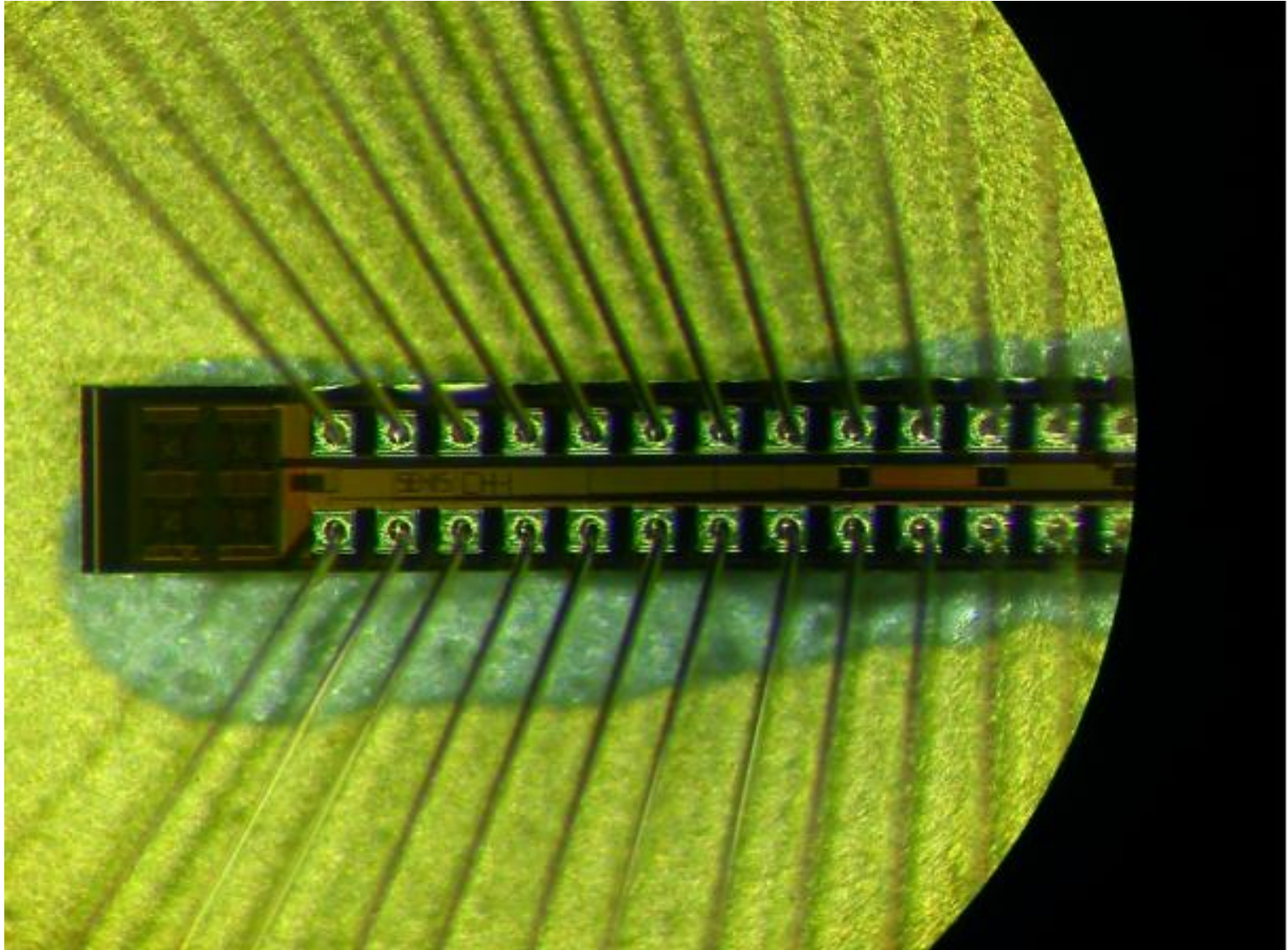

# Integrated Vertical Hall Element

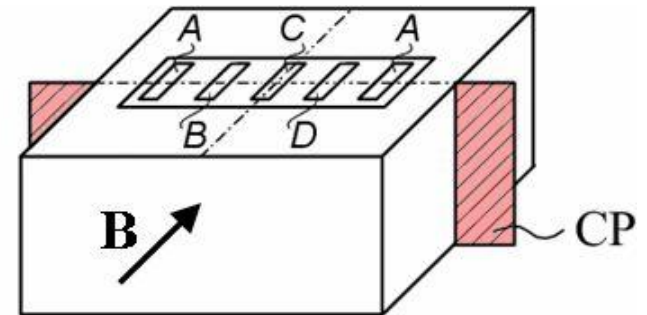
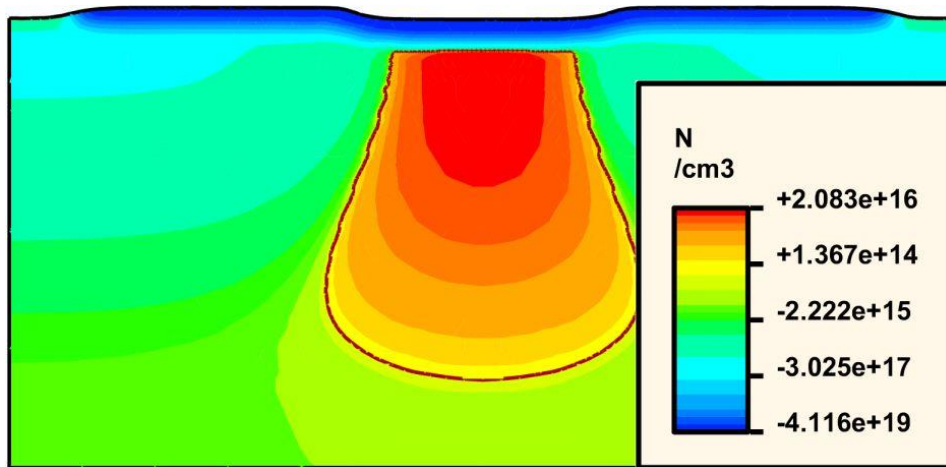

- Sensitive to in-plane field component  $B$
- CMOS Technology: N-Well
- Depletion Layer Isolation

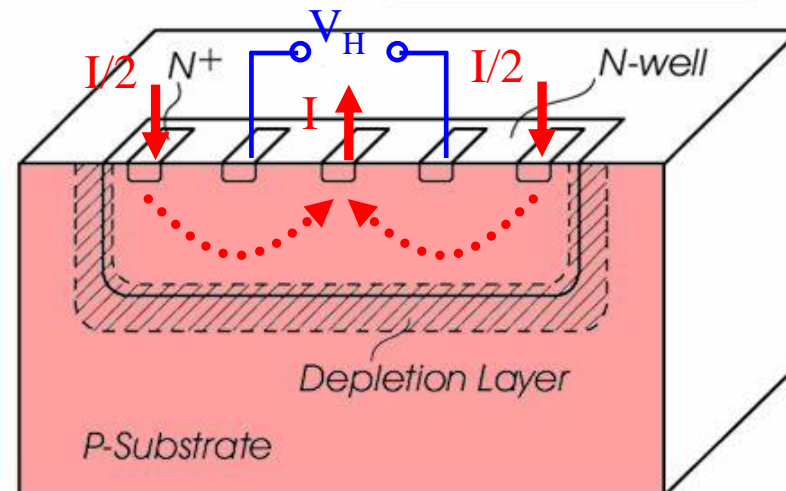

# Fully integrated 3D Hall probe

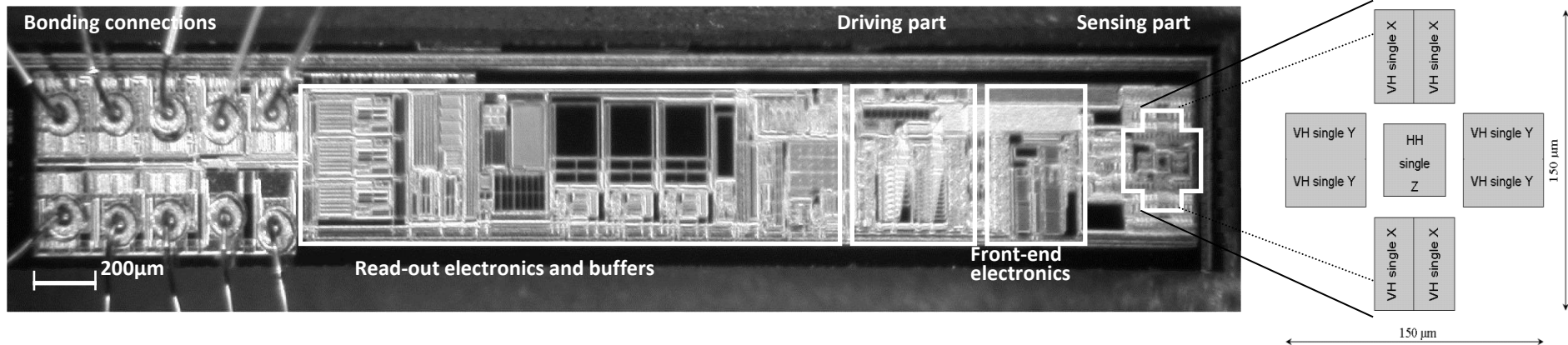

## Precise 3D magnetic field measurements

- from militeslas up to tens of tesla
- in the frequency range from DC to 30 kHz
- spatial resolution of about  $150\mu\text{m}$
- die dimensions:  $4300\mu\text{m} \times 640\mu\text{m} \times 550\mu\text{m}$

## Sensing part: two types of Hall devices

- a planar Hall device – for  $B_y$
- 8 vertical Hall devices – for  $B_x$  and  $B_z$

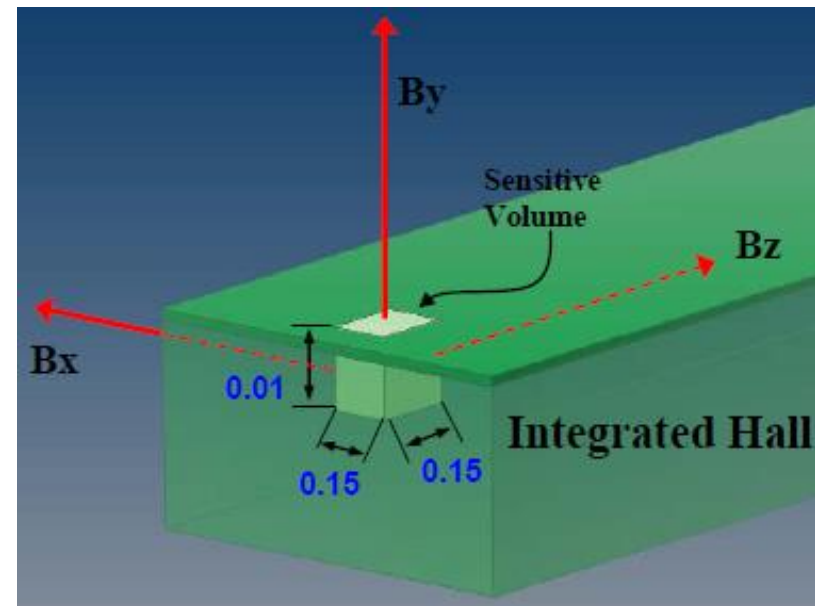

# SENIS 3-Axis Analog and Digital Teslameters

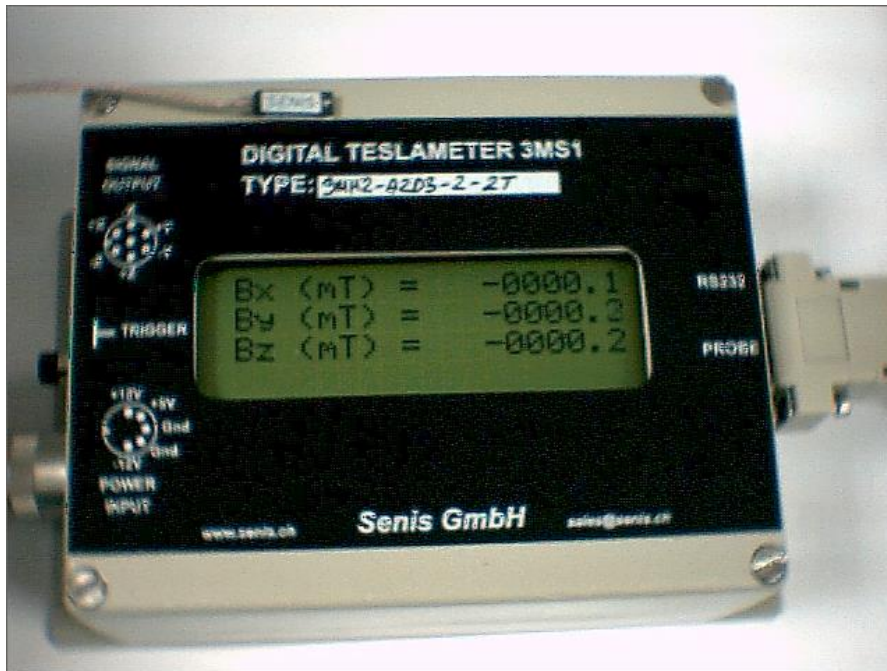

# Applications of 3-Axis Hall Teslameters

- Magnetic Field Mapping, e.g. in Particle Accelerators
- Characterization of Permanent Magnets
- Condition Monitoring of Electrical Machines

**SENIS**

3-Axis

Magnet Mapper

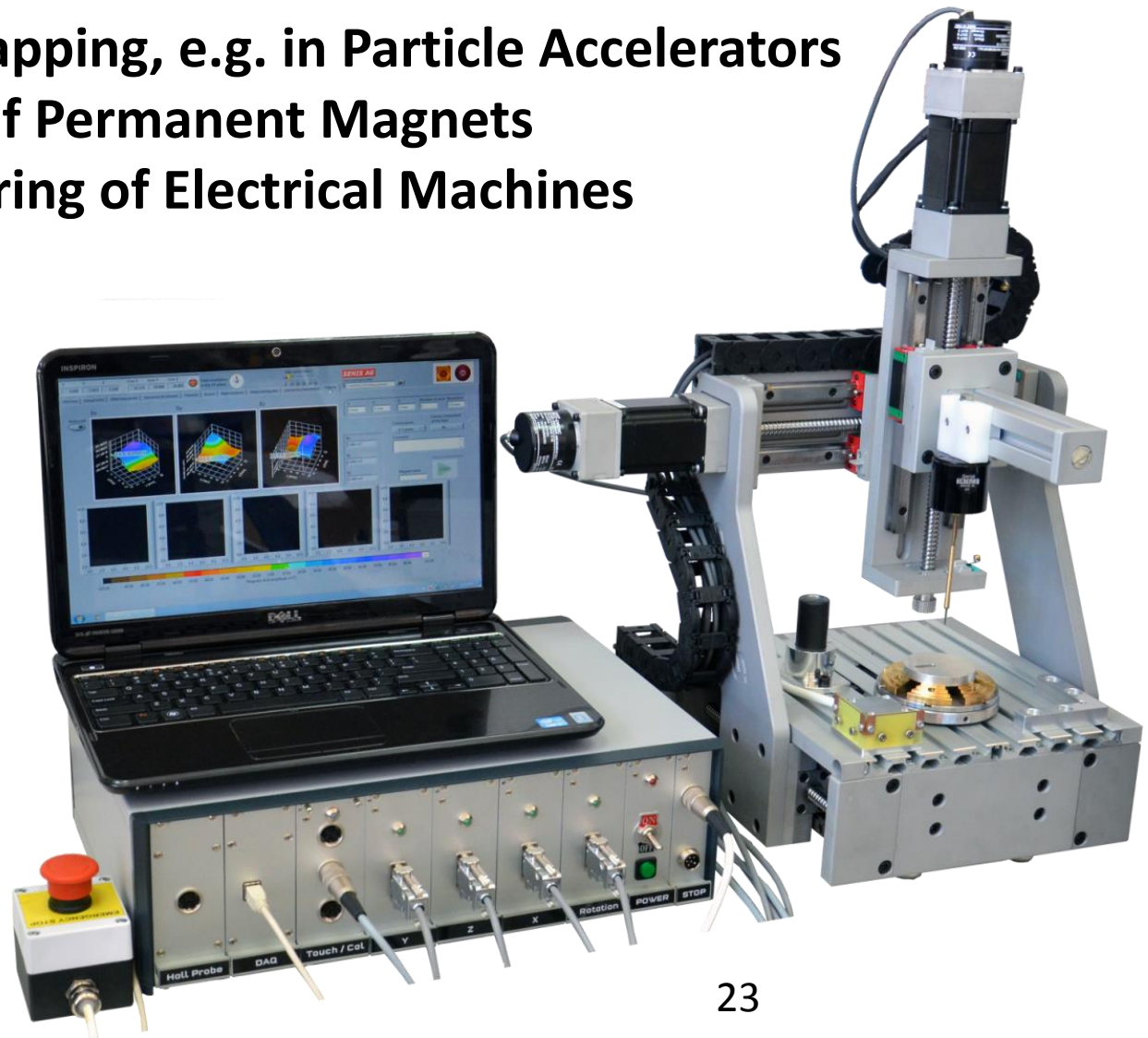

# Increasing Sensitivity of Hall Magnetic Sensor by Concentrating Magnetic Flux

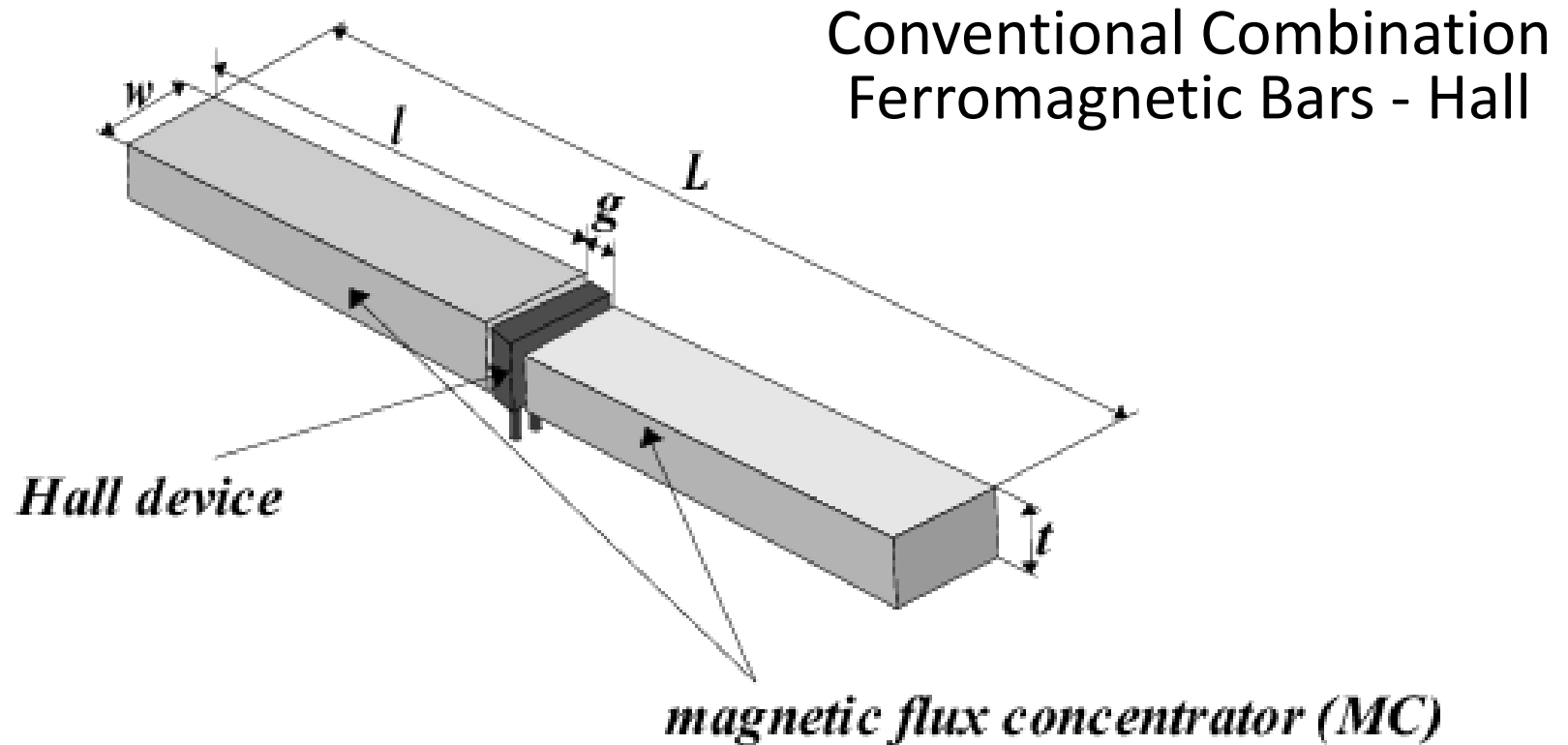



# Concept of Dual-Core IMC – Hall Sensor

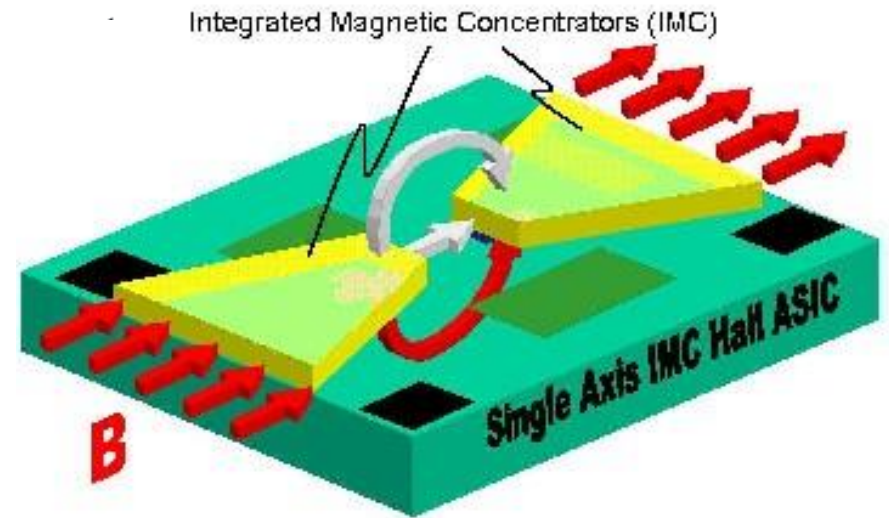
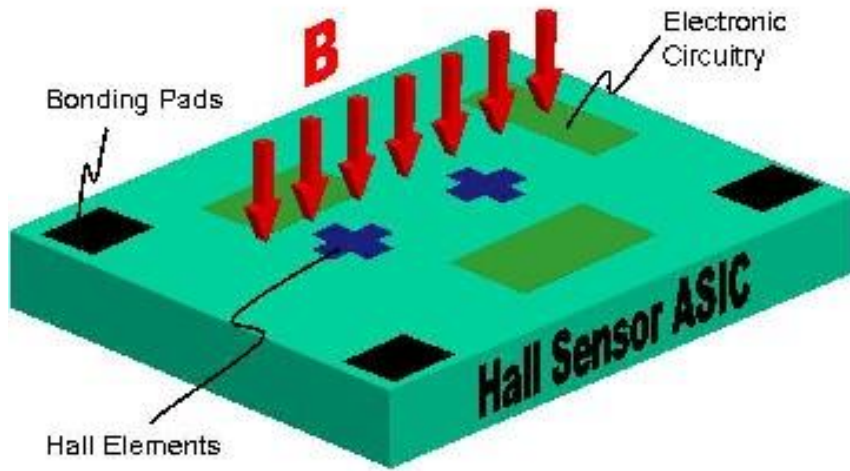
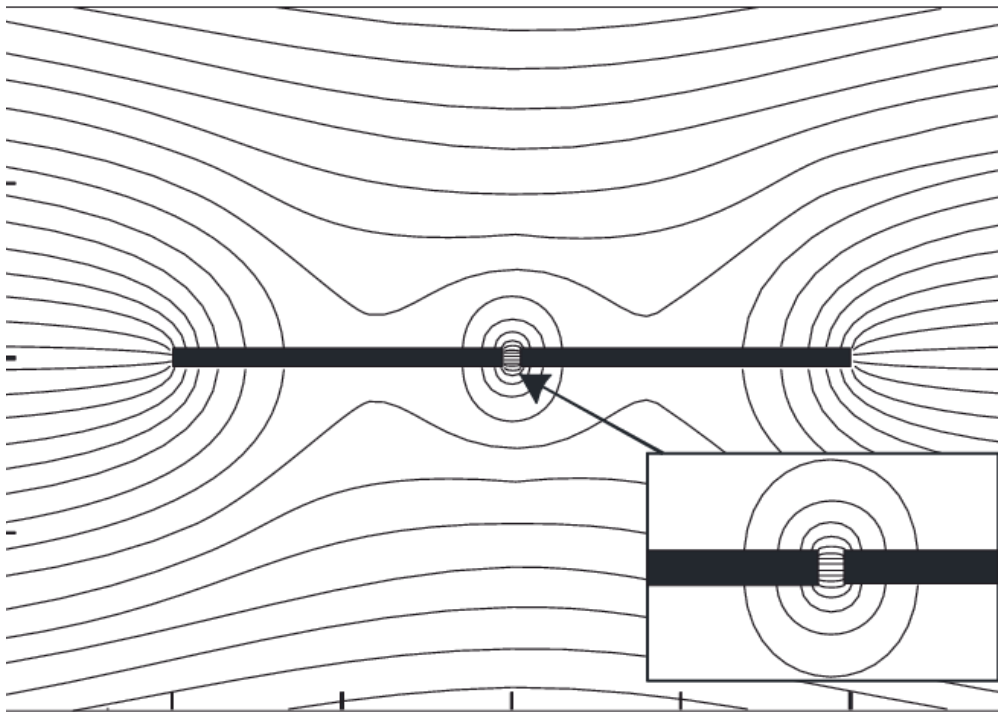



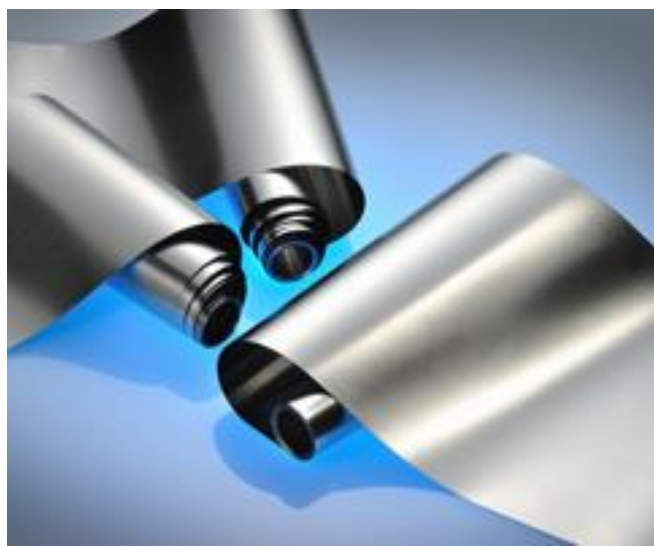

# Hybrid IMC-Hall Technology: Integrating High-Permeability Foil (Amorphous or Nano-Crystalline Metal) with CMOS Wafer

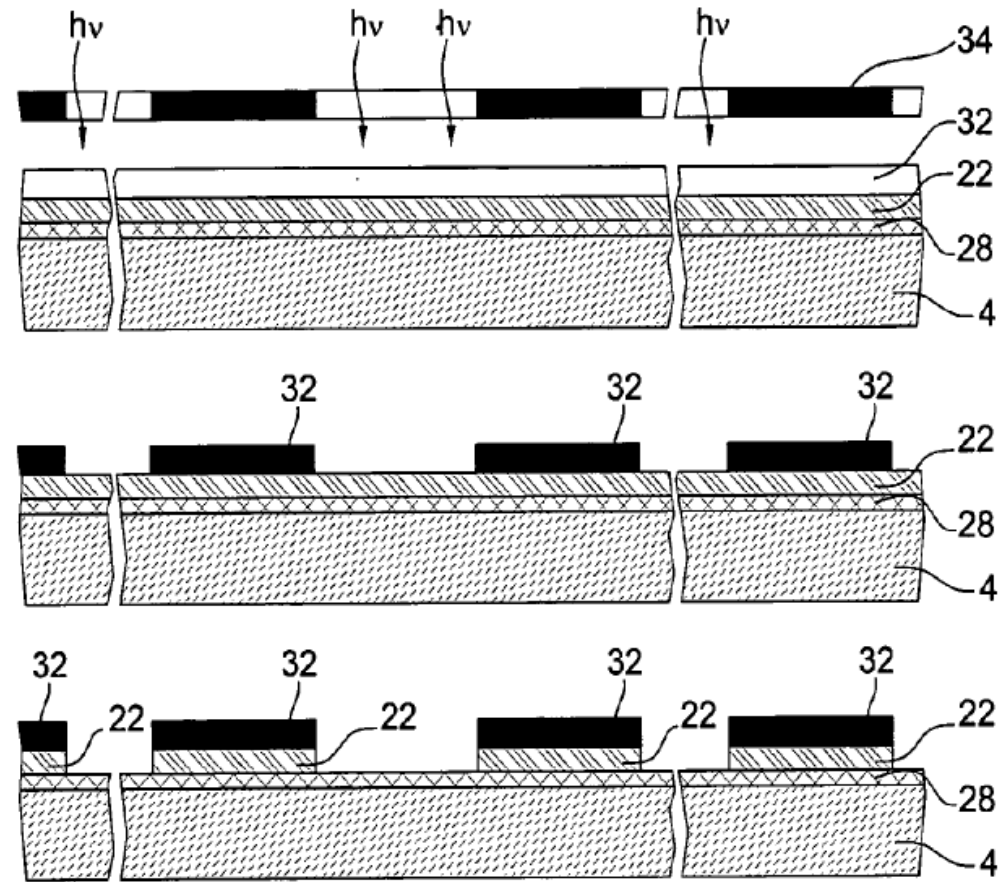
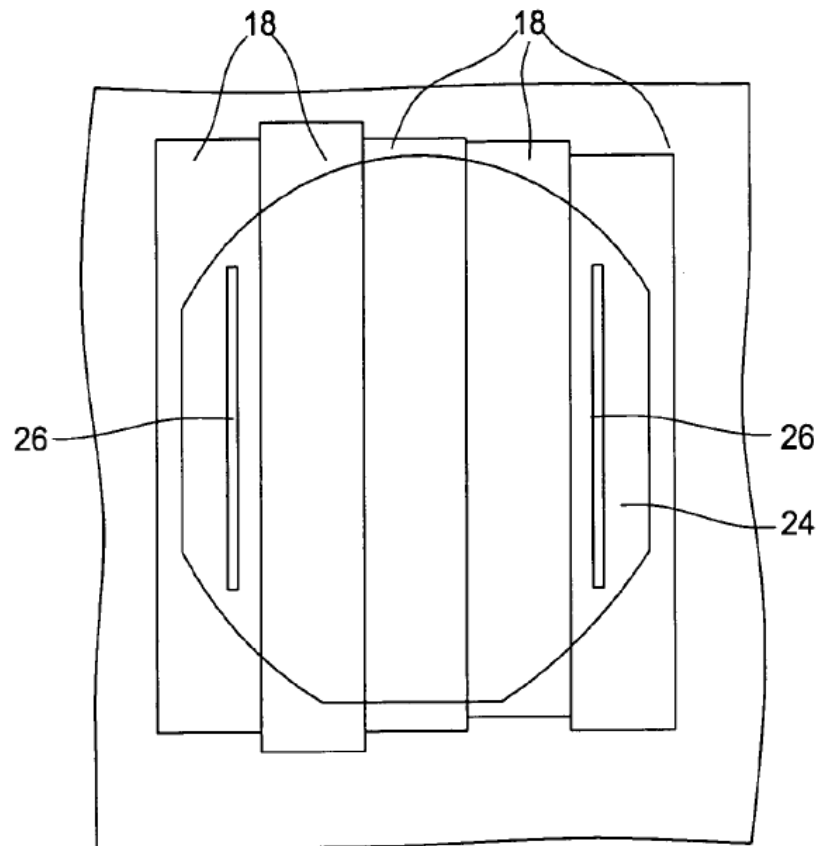

# Low Cost Current Sensor

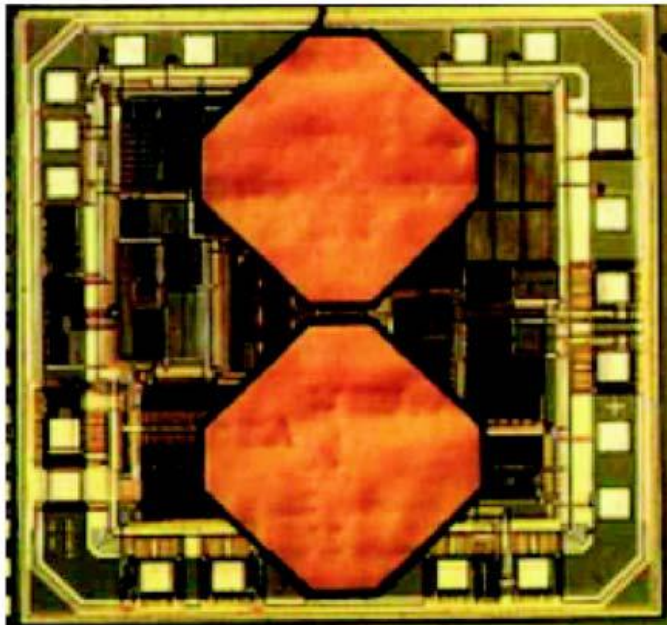
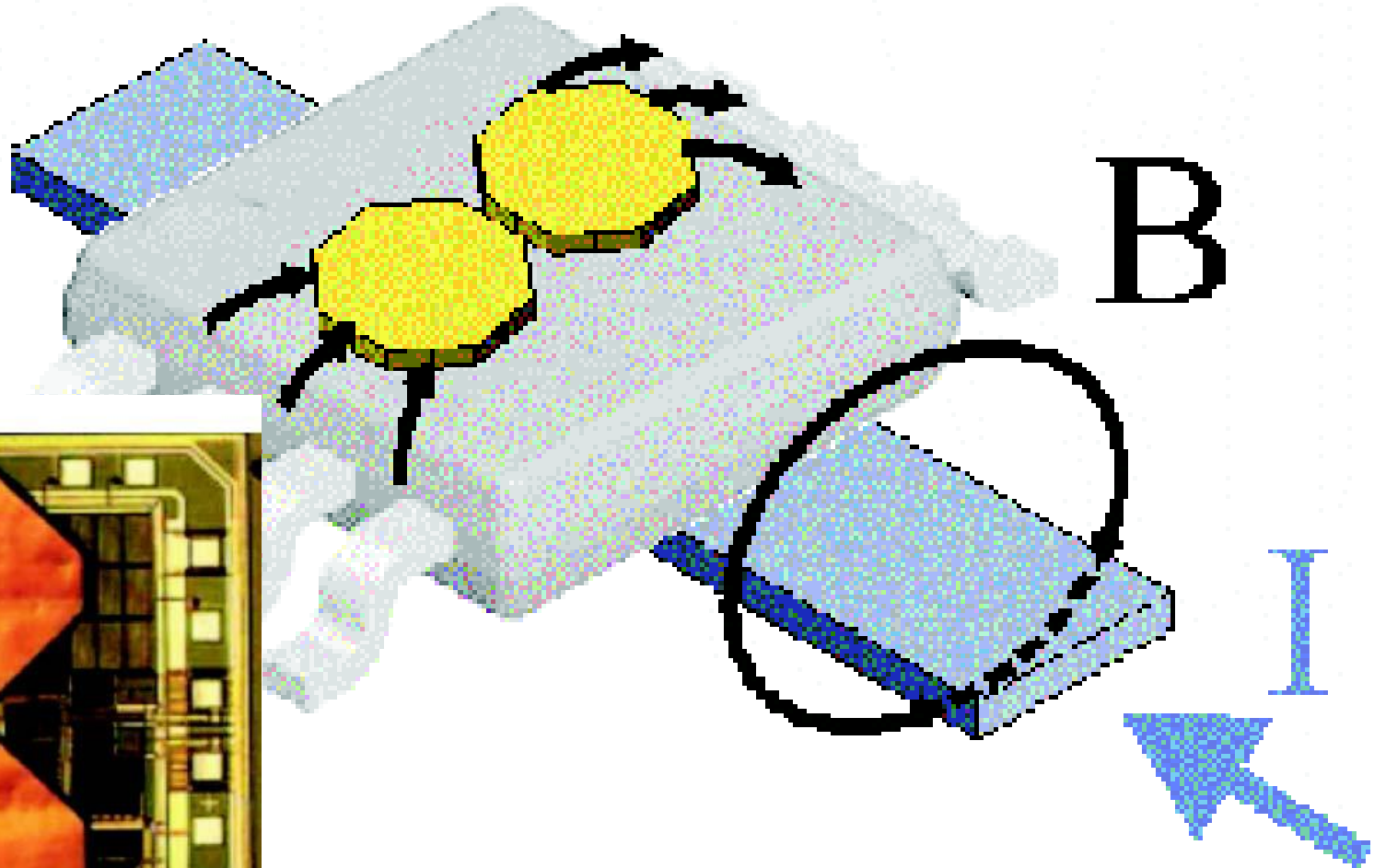

# **SENIS** Bus Bar Module Current Sensor

$I = 200A \dots 3000A$

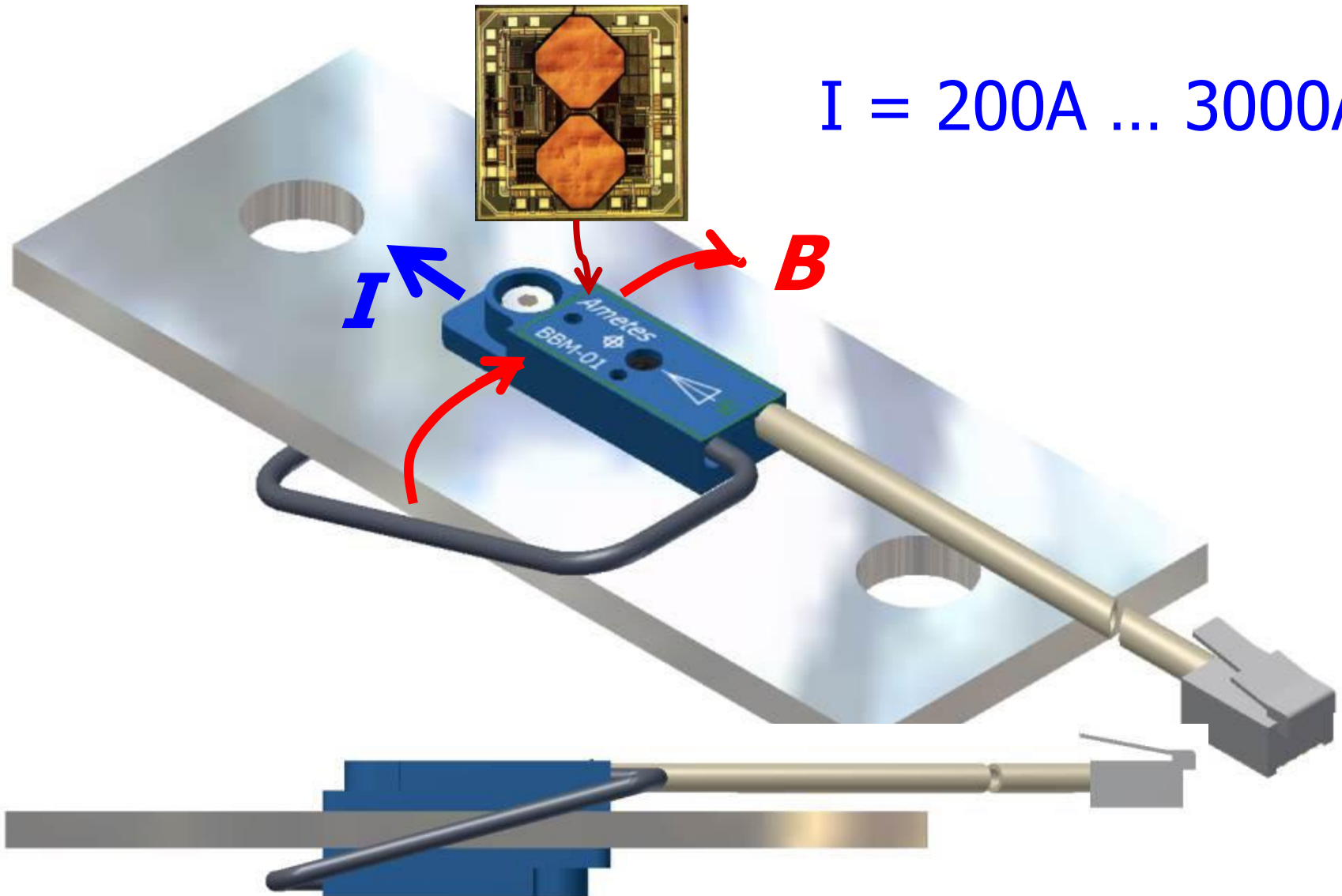

# Single-Core IMC-Hall

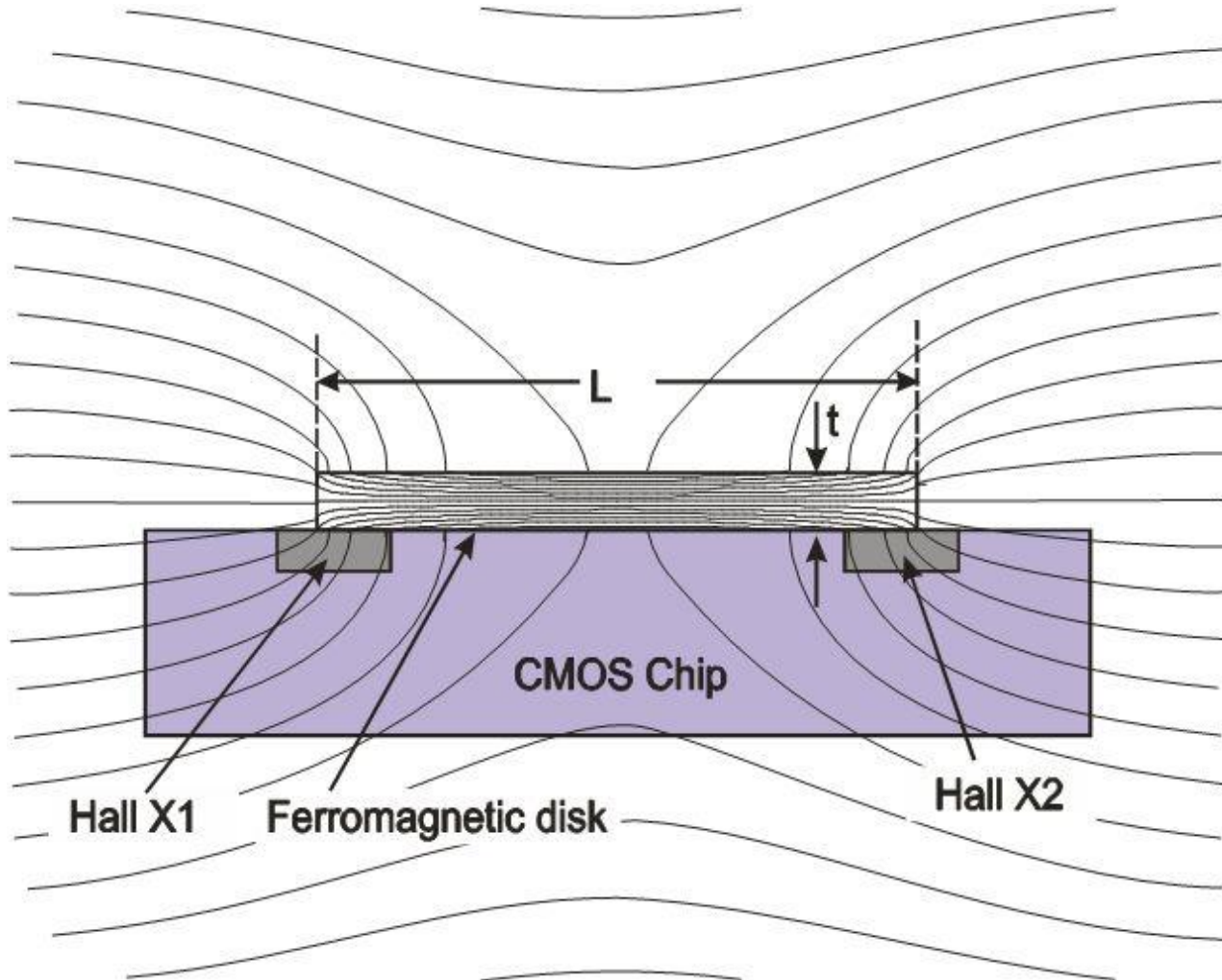

# 2 or 3-axis Hall magnetic sensor based on the IMC technology

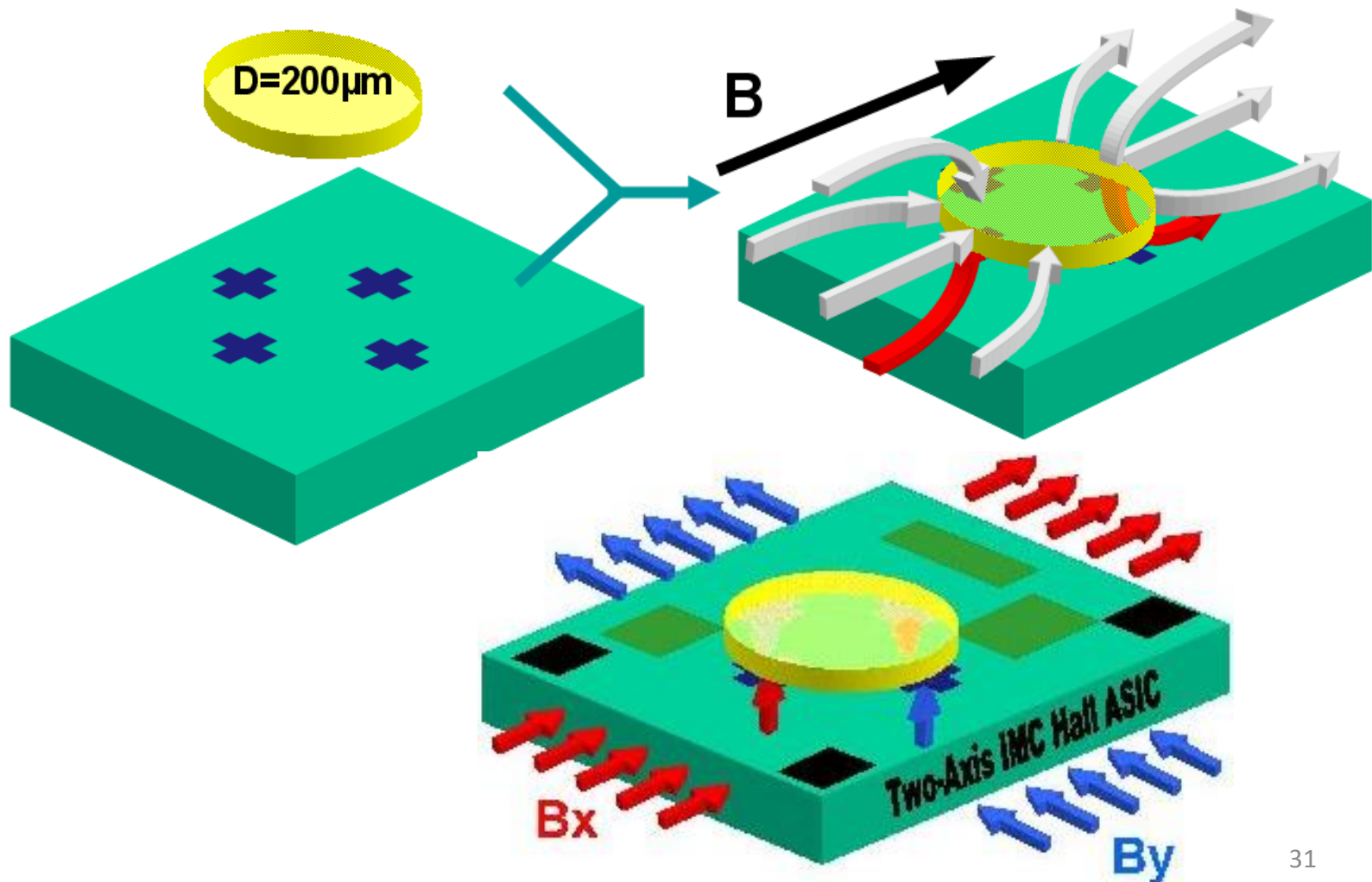

# SENTRON's 2-axis IMC-Hall ASIC

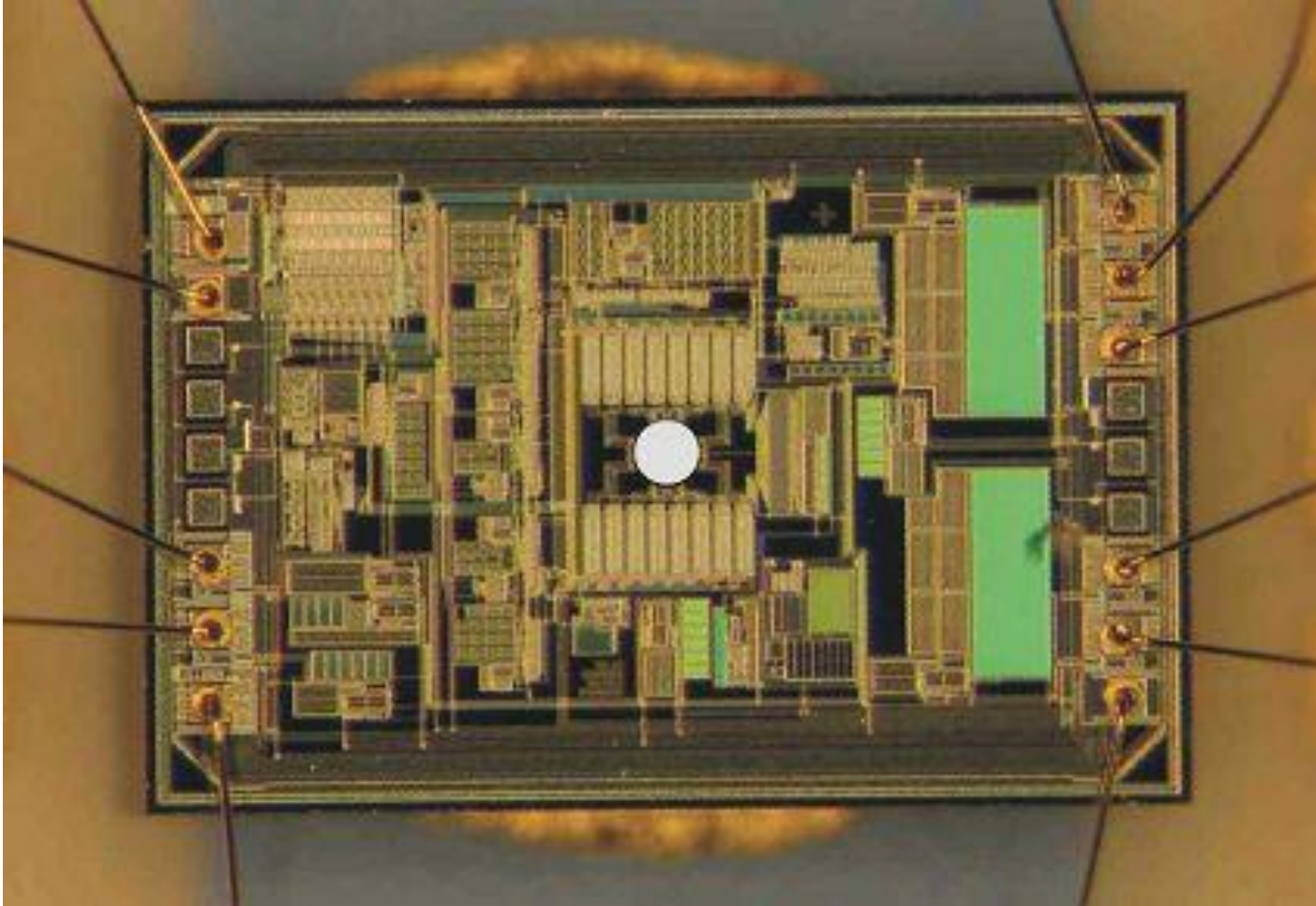



# Application: Angular Position Sensor

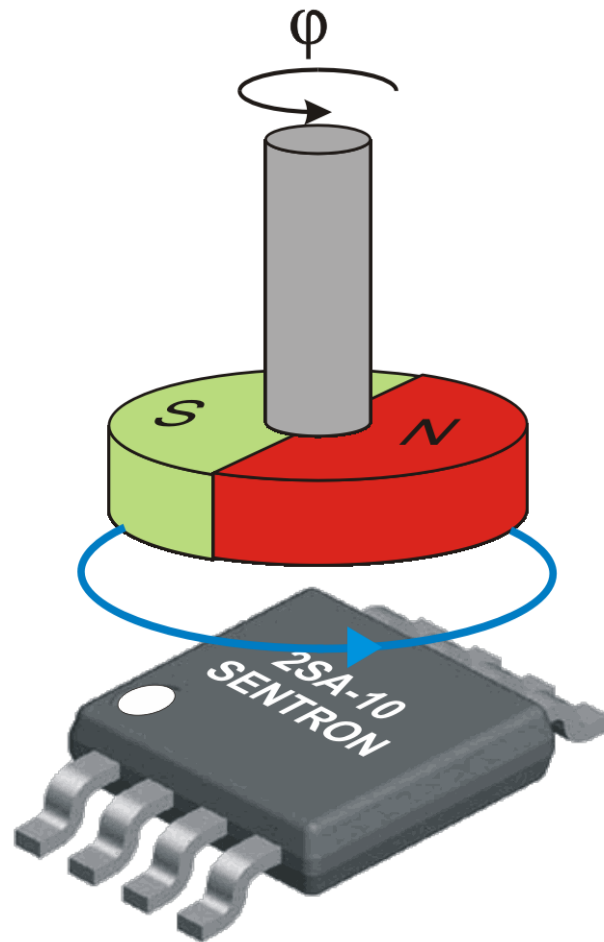

***2-axis IMC-Hall® ASIC (Sentron AG)***

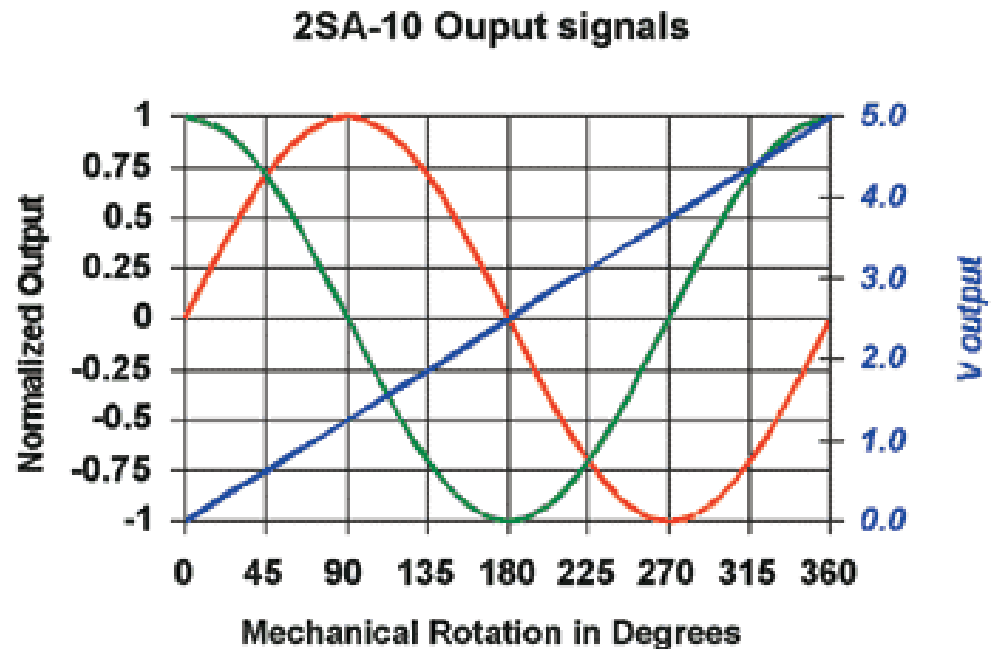

***2-axis IMC-Hall® ASIC Output signals***

# 3-axis IMC Hall ASIC: Structure

- ◉ CMOS 0.35 $\mu$ m
- ◉ 1.9 x 2.8 mm<sup>2</sup>

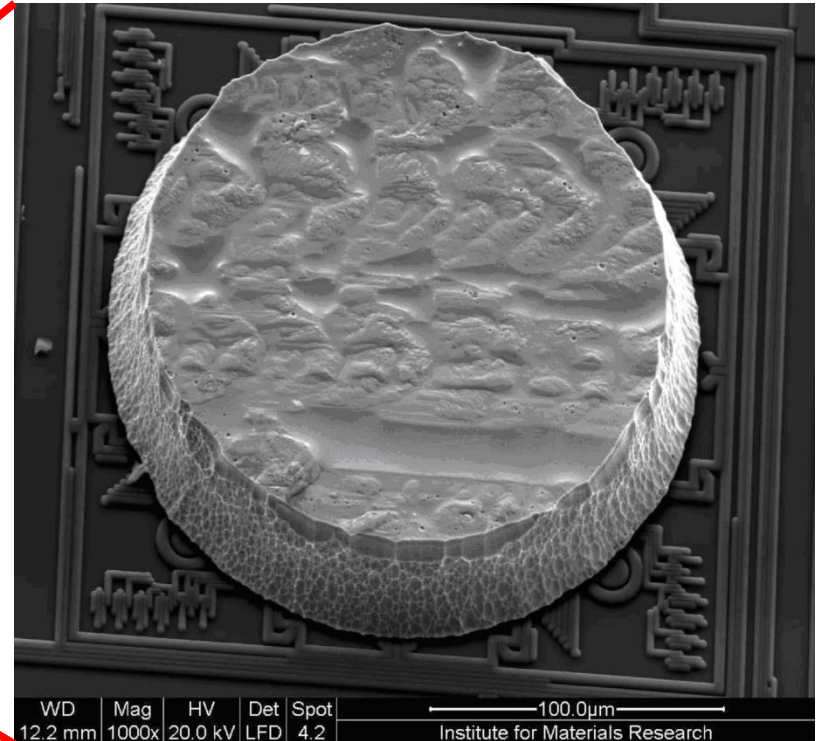
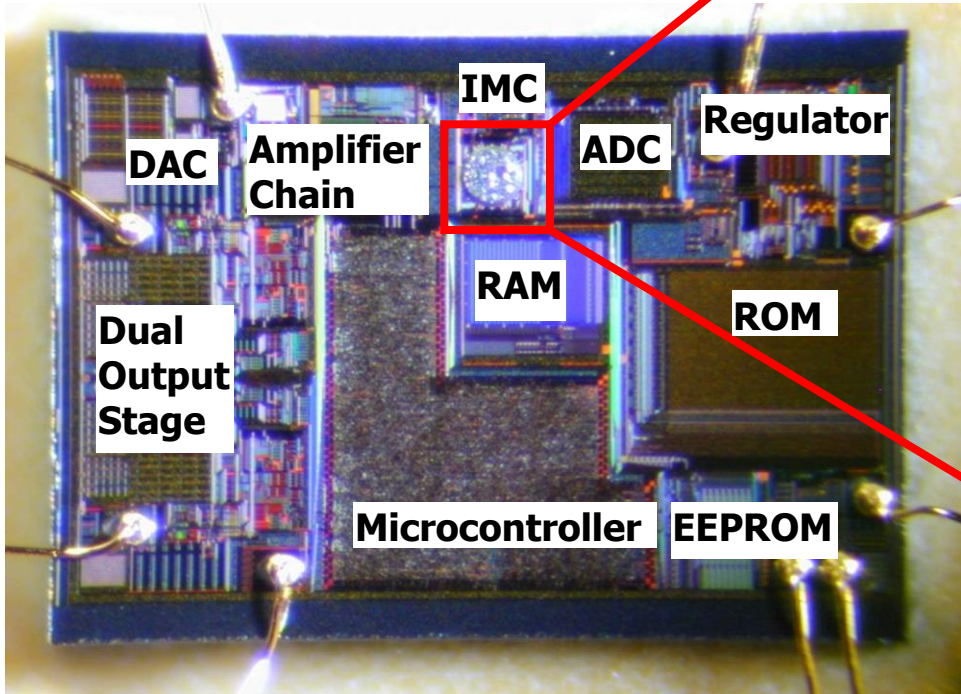

**Triaxis® Hall ICs**  
Type MLX90316



# 3-axis IMC Hall ASIC: Application

- Accelerator and brake pedal position sensors
- Throttle position sensor
- Steering wheel position sensor
- Height sensor
- Float level sensor
- Non-contacting potentiometer
- Motor shaft position

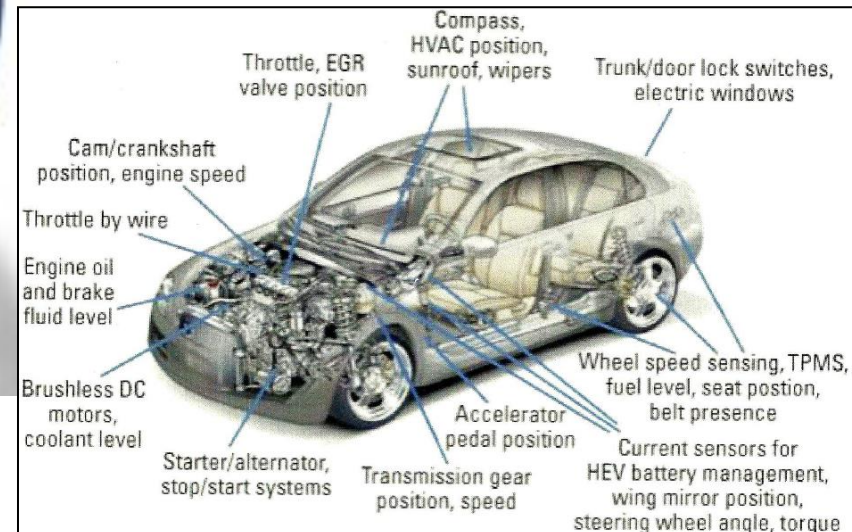
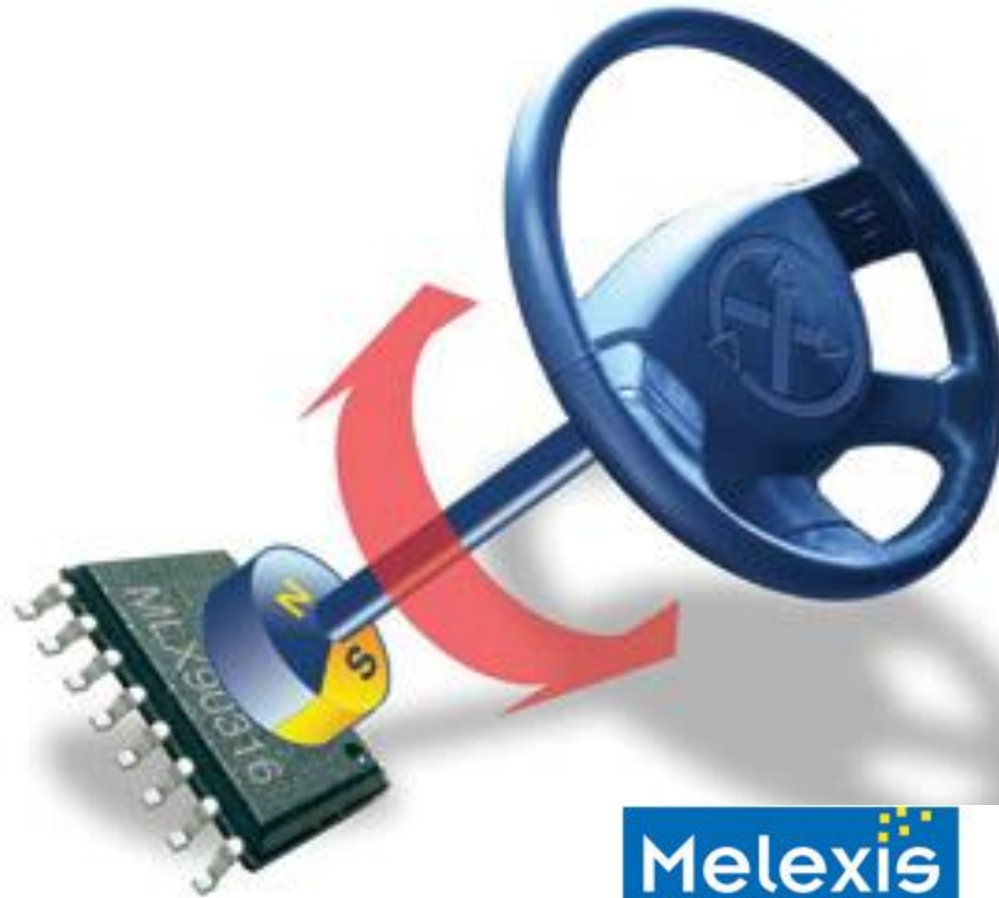

# The basis of the AKM E-Compass

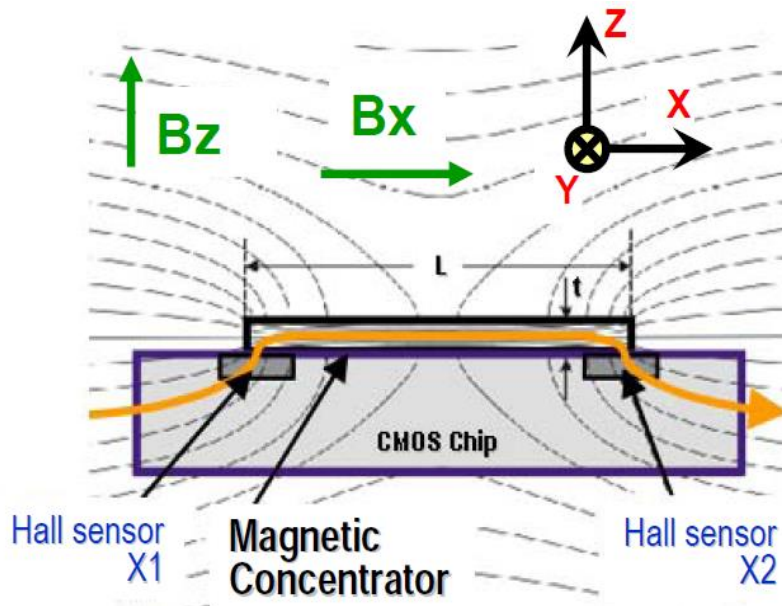

**The IMC Technology**

**&**

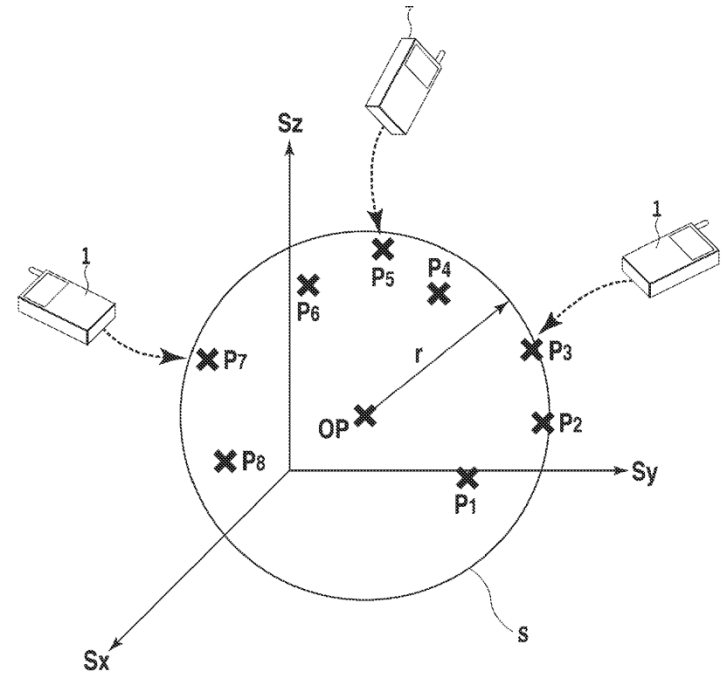

**The Dynamic Offset Estimation Algorithm**

# AK8973 Die Photo



Magnetic Concentrator

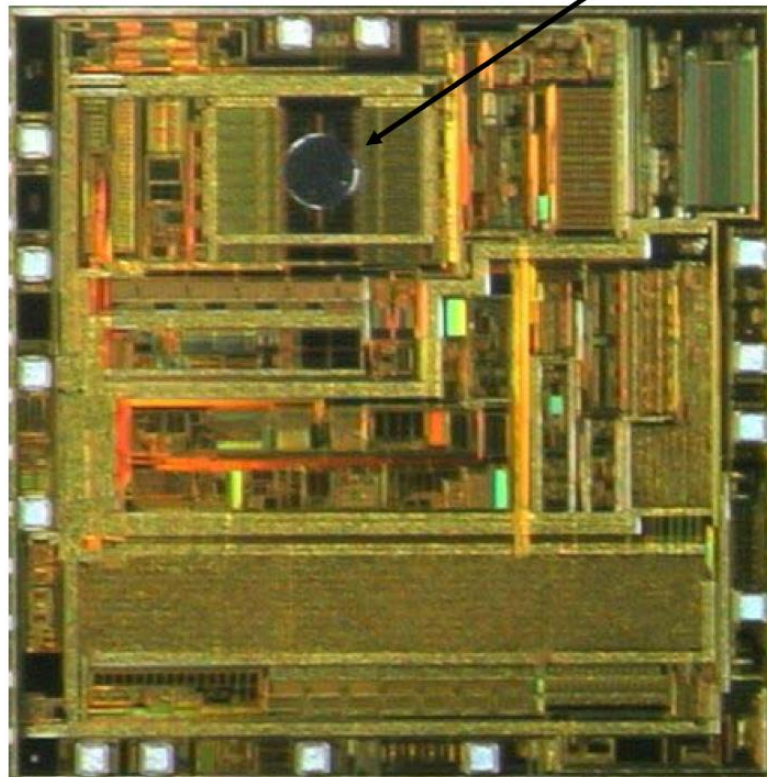

# AK8975 Magnetic Concentrator Cross-Section

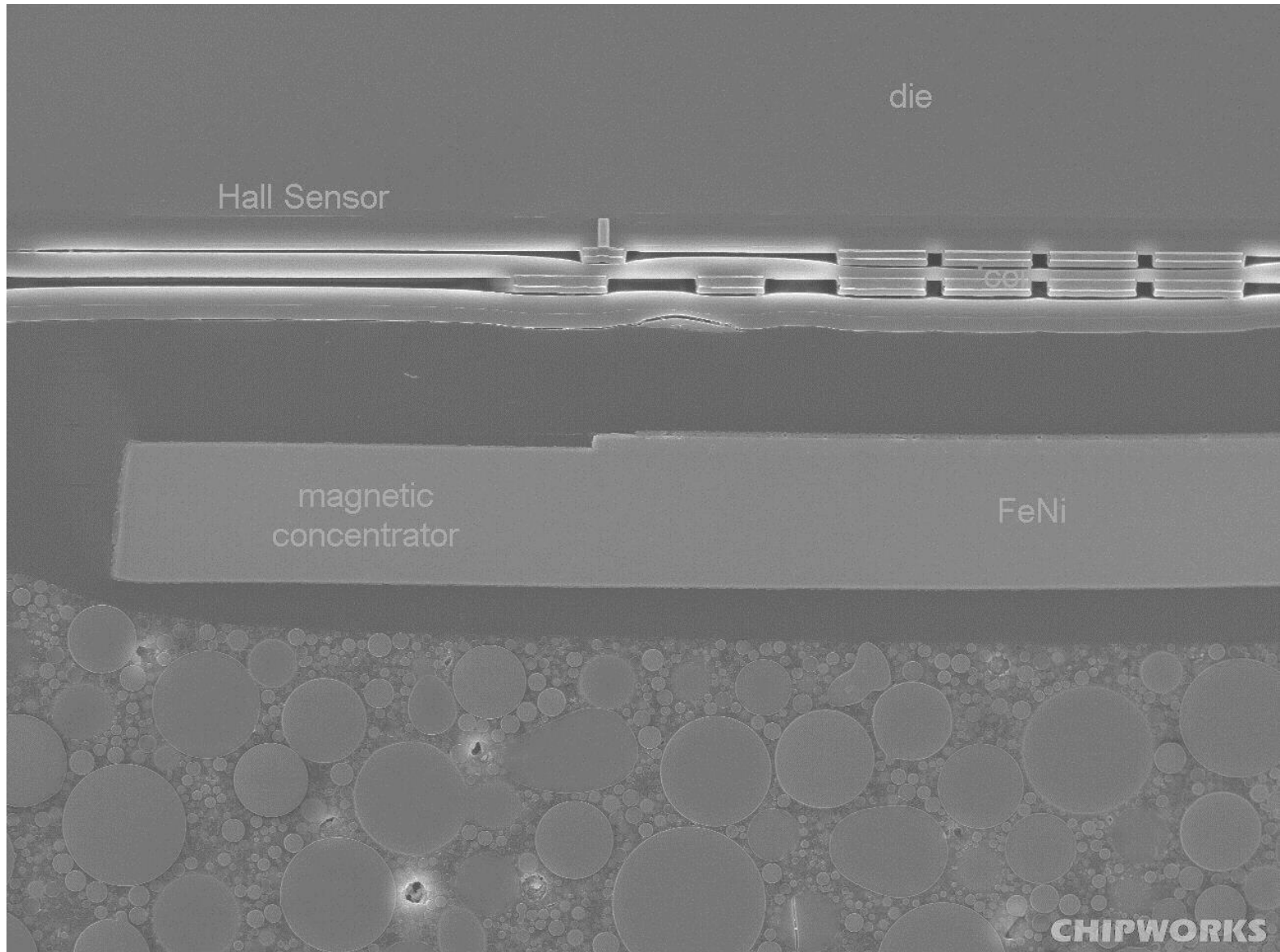

# Conclusions

- Hall devices can be integrated with CMOS electronics
- In a single chip, all three components of magnetic field vector can be measured
- Integrated Hall ICs are the most used magnetic sensors
- Dominant applications: automotive and smart phones
- Designer of Hall IC needs more process parameters than designer of IC electronics
- The missing parameters can be retrieved by reverse engineering
- Production of Hall ICs may include post-processing of finished IC wafers, additional testing, and special packaging